

HOST

Bar Blender

Instruction manual

Model:

HT237 (HOST0645BN)

HT235 (HOST0646BS)



Read this instruction
manual carefully
before use

Safety Instructions

- Position on a flat, stable surface.
- A service agent/qualified technician should carry out installation and any repairs if required. Do not remove any components or service panels on this product.
- Consult Local and National Standards to comply with the following:
 - Health and Safety at Work Legislation
 - BS EN Codes of Practice
 - Fire Precautions
 - IEE Wiring Regulations
 - Building Regulations
- DO NOT use jet/pressure washers to clean the appliance.
- DO NOT immerse the appliance in water.
- This appliance is only used for blending food. Do not use the appliance for anything other than its intended use.
- Always switch off and disconnect the power supply to the appliance when not in use.
- Not suitable for outdoor use.
- Keep all packaging away from children. Dispose of the packaging in accordance with the regulations of local authorities.
- If the power cord is damaged, it must be replaced by a recommended qualified technician in order to avoid a hazard.
- This appliance is not intended for use by persons (including children) with reduced physical, sensory or mental capabilities, or lack of experience and knowledge, unless they have been given supervision or instruction concerning the use of the appliance by a person responsible for their safety.
- Children should be supervised to ensure that they do not play with the appliance.

- Do not let cord hang over edge of table or counter, or touch hot surfaces.
- Keep hands and utensils out of the jug while motor is running to prevent severe personal injury and / or damage to the blender.
- **Blade is sharp – handle carefully.**
- Do not operate with loose or damaged blades.
- Do not place jug on to base with On/Off switch in the On position.
- Always operate with lid in place.
- Only use original parts and attachments supplied with this appliance.
- Do not blend hot liquids.
- Do not blend dry ingredients.
- Keep the appliance and its cord out of reach of children.
- Do not leave blender unattended while in use.
- HOST recommend that this appliance should be periodically tested (at least annually) by a Competent Person. Testing should include, but not be limited to: Visual Inspection, Polarity Test, Earth Continuity, Insulation Continuity and Functional Testing.
- HOST recommend that this product is connected to a circuit protected by an appropriate RCD (Residual Current Device).

Operation

Model: HT237 (HOST0645BN)

Model: HT235 (HOST0646BS)

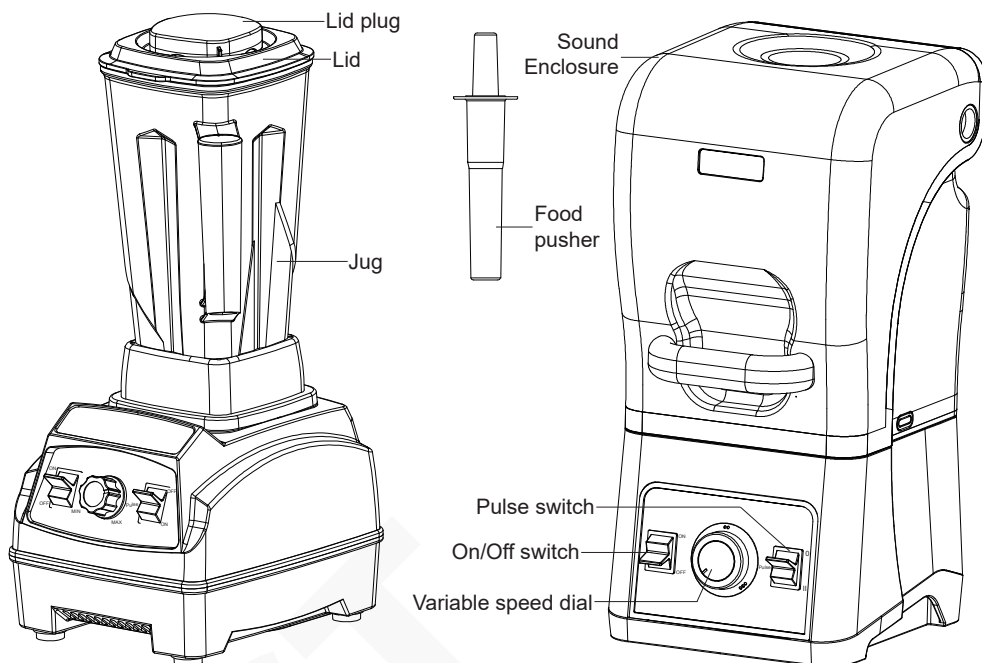

Controls

- On/Off switch: Up for On (ON), down for Off (OFF).
- Variable Speed Dial: Allows continual adjustment of speed from MIN/● to MAX/●●●●.
- Pulse Switch: Down to pulse at FULL speed (ON/II).

Blending

Before use, ensure to

- Clean all removable parts thoroughly.
- Turn off On/Off switch (OFF position).

1. Plug in blender.
2. Place ingredients into the jug.
3. Secure the lid and lid plug (**Note: Always operate with the lid secured**).
4. Locate jug on the body of blender.
5. Select speed using variable speed dial.
6. Turn on blender using On/Off switch.
7. Using the pulse function: Set the Pulse switch to ON/II position and hold to start pulse function. Release to stop.

Note: When blending hard ingredients best results will be obtained by cutting ingredients into small pieces and adding to the blender through the hole in the lid when motor is running.

Before removing jug, ensure to turn off blender using On/Off switch and let the motor come to a complete stop.

Cleaning, Care & Maintenance

- Always disconnect from power supply before cleaning.
- Always allow to cool before cleaning.
- Let the motor come to a complete stop before removing the jug.
- The jug is NOT dishwasher proof!
- Use warm, soapy water and a damp cloth to clean the jug.
- Dry thoroughly after cleaning.

WARNING: Blade is sharp! Be careful when emptying the jar and during cleaning.

Do not allow any water to spill into the body of the appliance when cleaning.

Never attempt to remove the blade assembly from the jar for cleaning as its removal requires special tools and can only be carried out by our service personnel.

Cleaning the jug and blade assembly

- Add water and mild detergent into the jug, then locate the lid and lid plug.
- Secure the jug on the body and switch on at FULL speed for 10-20 seconds.
- Switch off and remove the jug, then rinse with clean water thoroughly. Ensure no water will get contact with the underside of the jug.

Troubleshooting

A qualified technician must carry out repairs if required.

Fault	Probable Cause	Solution
The appliance is not working	The unit is not switched on	Check the unit is plugged in correctly and switched on
	Plug or lead is damaged	Replace plug or lead
	Fuse in the plug has blown	Replace the fuse
	Mains power supply fault	Check mains power supply
	Jug incorrectly located on body of appliance	Relocate jug
Unit stops working suddenly	Motor overheating protection is activated	Switch off and unplug. Wait to let the motor to cool sufficiently, then restart

Service

Should your appliance have a fault, please visit the Service section of the HOST website:

<https://www.host-appliances.com/repairs>

Technical Specifications

Model	Voltage	Power	Current	Jug Capacity	Dimensions (H x W x D) (mm)	Net Weight
HT237 (HOST0645BN)	220-240V~ 50/60Hz	1100W	5A	2L	535 x 200 x 220	3.9kg
HT235 (HOST0646BS)		1500W	6.5A	2L	480 x 210 x 235	7.1kg

Due to our continuous improvement process, the product specifications are subject to change without notice.

Electrical Wiring

The appliance is supplied with a 3 pin BS1363 plug and lead.

The plug is to be connected to a suitable mains socket.

The appliance is wired as follows:

- Live wire (coloured brown) to terminal marked L
- Neutral wire (coloured blue) to terminal marked N
- Earth wire (coloured green/yellow) to terminal marked E

This appliance must be earthed.



If in doubt consult a qualified electrician.

Electrical isolation points must be kept clear of any obstructions. In the event of any emergency disconnection being required they must be readily accessible.

Compliance

The WEEE logo on this product or its documentation indicates that the product must not be disposed of as household waste. To help prevent possible harm to human health and/or the environment, the product must be disposed of in an approved and environmentally safe recycling process. For further information on how to dispose of this product correctly, contact the product supplier, or the local authority responsible for waste disposal in your area.



HOST parts have undergone strict product testing in order to comply with regulatory standards and specifications set by international, independent, and federal authorities.

HOST products have been approved to carry the following symbol:



All rights reserved. No part of these instructions may be produced or transmitted in any form or by any means, electronic, mechanical, photocopying, recording or otherwise, without the prior written permission of HOST. Every effort is made to ensure all details are correct at the time of going to press, however, HOST reserve the right to change specifications without notice.

HOST

Declaration of Conformity

We {Host} of {Host House, Newhouse Farm Industrial Estate, Mathern, Chepstow, NP16 6UP} hereby declare that the equipment is in conformity with the requirements of the following Regulations:

- **Low Voltage Directive (LVD) - 2014/35/EU**
Electrical Equipment (Safety) Regulations 2016
- **Electro-Magnetic Compatibility (EMC) Directive 2014/30/EU - recast of 2004/108/EC**
Electromagnetic Compatibility Regulations 2016 (S.I. 2016/1091)
- **Restriction of Hazardous Substances Directive (RoHS) 2015/863 amending Annex II to Directive 2011/65/EU**
The Restriction of the Use of Certain Hazardous Substances in Electrical and Electronic Equipment Regulations 2012 (S.I. 2012/3032)
- **Regulation (EC) No 1935/2004- Food Contact Materials (FCM)**
Regulation (EC) No 1935/2004 on Materials and Articles intended to Come into Contact with Food

We hereby declare that:
Equipment Model number:

HT237(HOST0645BN) Bar Blender - 2Ltr
HT235(HOST0646BS) Bar Blender - 2Ltr with sound enclosure

is in conformity with the applicable requirements of the following documents:

Ref. No.	Edition/date
EN 60335-1	2012 +A11:2014 +A13:2017 +A1:2019 +A2:2019 +A14:2019 +A15:2021
EN 60335-2-14	2006 +A1:2008 +A11:2012 +AC:2013 +A12:2016
EN 62233	2008
EN IEC 61000-3-2	2018 +A1:2020
EN IEC 61000-3-3	2013 +A1:2017 +A2:2021
CISPR 14-1	2020
CISPR 14-2	2020

I hereby declare that the equipment named above has been designed to comply with the relevant sections of the above referenced specifications and is in accordance with the requirements of the Regulations:

Signed by:

Signed by:

AB6DB7656FFB441...

Full Name Ashley Hooper
Title: Group Head of Product
 Quality & Compliance
Location: Bristol, United Kingdom
Date: 20TH Nov 2025





www.host-appliances.com

HT237 (HOST0645BN)_HT235 (HOST0646BS)_EN_A5_v3_2025/12/04