



WATER



GAS



ENVIRONMENT



PEST CONTROL

INTRODUCING...

HYGENIKX+™

The ultimate air and surface steriliser, now available for occupied areas



KILLS DISEASE CAUSING AIRBORNE PATHOGENS

PREVENTS THE SPREAD OF VIRUSES & BACTERIA

TARGET & ELIMINATE HARMFUL BACTERIA

KEEP THE WORKING ENVIRONMENT SAFE FOR YOUR STAFF AND CUSTOMERS

KILLS INFLUENZA VIRUSES, E.COLI, NOROVIRUS and other primary sources of infections

Help protect staff and visitors +

HyGenikx™ is an advanced and compact, wall mounted sterilisation system, with proven technology that can eradicate viruses and bacteria throughout the office and other occupied areas.

Flu viruses can survive as droplets in the air for several hours, and on surfaces for several days if the conditions are right. HyGenikx will significantly improve hygiene to levels impossible to achieve with traditional cleaning methods alone, which helps to reduce the transmission of infectious diseases and staff absenteeism.



WATER



GAS



ENVIRONMENT



PEST CONTROL

THE ULTIMATE AIR & SURFACE STERILISER SYSTEM

HYGENIKX+

The HyGenikx range features and benefits:

- 24/7 infection control
- Kills *Escherichia coli* (E. coli), *Staphylococcus aureus* (S. aureus), *Clostridium difficile* (C. difficile), *Aspergillus fumigatus*, and other primary sources of infections
- Significantly improves hygiene standards to levels impossible to maintain with traditional cleaning methods alone
- Eradicates unpleasant odours by tackling them at source
- Eliminates bacteria, viruses, moulds, fungi and volatile organic compounds (VOCs), both in the air and on exposed surfaces, even in the hardest to reach places
- Safe to use & for the environment
- Improves infection control for staff and visitors
- Reduces staff absenteeism
- Easy to change lamp and backup battery, **requires no onsite engineer**
- Low power consumption, 9-13W
- Utilises a combination of the **most effective** air and surface sterilisation technologies available
- Power via a plug* that allows flexible installation and **easy connection to existing sockets or to switched spurs**
- Available in a choice of **white or titanium** finish



OFFICE & SMALLER AREA MODELS

	WHITE finish	TITANIUM finish
10-20m ²	HGX-W-05-O	HGX-T-05-O
20-40m ²	HGX-W-25-O	HGX-T-25-O

These two models are available for use in occupied areas, such as offices, corridors and reception areas, with low ventilation and air movement.

Note: These units can be used in multiples, covering a maximum area of 80m².

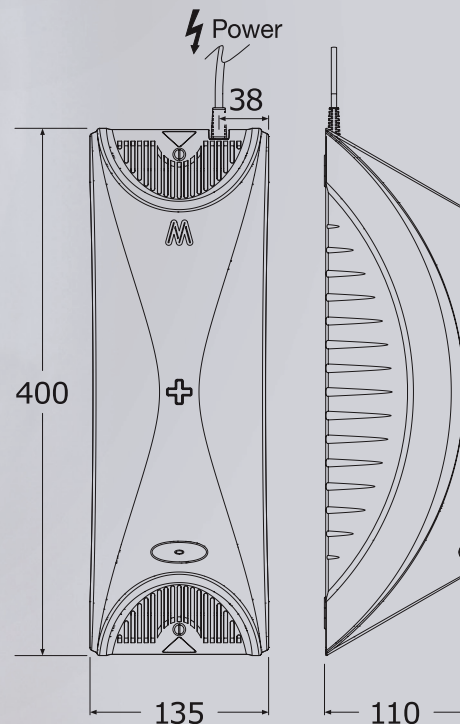

SPECIFICATION

- Combines technologies: Gericidal Oxidation, Gericidal Irradiation, Dual waveband Plasma Quatro
- Services: 220/50/1. Uninterrupted supply – 24 hour operation required. High level
- 1.8m power cable with plug* to be connected to suitably isolated socket or fused spur
- EC declaration of conformity
- CE mark
- Low Voltage Directive (LVD) 2014/35/EU
- Electromagnetic Compatibility Directive (EMC) 2014/30/EU
- Manufactured in accordance with European standards
- Produced under the control of our comprehensive BSI ISO 9001:2015 Quality Management System (certificate FS 616985)
- Class 1 certified for electrical insulation
- Designed and manufactured to EUOTA (European Ozone Trade Association) requirements

*Plug type supplied is dependent on country/location. 3-pin (type G), or 2-pin (type C) Europlug.

For well ventilated commercial areas (foodservice, washrooms, changing rooms, refuse areas), please refer to our FOODSERVICE range