



**CHIPPER**

**INSTALLATION, OPERATING AND MAINTENANCE MANUAL**  
**PLEASE LEAVE WITH OPERATOR**



**CHIPPER – PC2 SERIES 4**

Imperial Machine Company Limited  
Unit 1, Abbey Road  
Wrexham Industrial Estate  
Wrexham LL13 9RF  
Tel: +44 (0)1978 661155  
Fax: +44 (0)1978 729990  
Service Fax: +44 (0)1978 667766  
Spares Fax: +44 (0)1978 667759  
E-mail: [info@imco.co.uk](mailto:info@imco.co.uk)  
Website: [www.imco.co.uk](http://www.imco.co.uk)

**A34/001 R14**

**ECN 8387 October 2015**

**EC DECLARATION OF CONFORMITY**  
(Guarantee of Production Quality)



We, Imperial Machine Company Limited of:  
Unit 1, Abbey Road, Wrexham Industrial Estate, Wrexham, LL13 9RF  
Declare under our sole responsibility that the machine

**CHIPPER – PC2 SERIES 4**

As described in the attached technical documentation is in conformity with the Machinery directive 98/37/EC (Formally 89/392/EEC) and is manufactured under a quality system BS EN ISO 9001 It is also in conformity with the protection requirements of the Electro Magnetic Compatibility Directive 2004/108/EC and is manufactured in accordance with harmonised standards EN61000-6-1:2001 Immunity and EN61000-6-3:2001 Emissions (plus product specific standards). IMC's product range also satisfy the essential health and safety requirements of the Low Voltage Directive 2006/95/EC and are manufactured in accordance with standards BS EN 60335-1 and relevant product specific standards.

Approved by E Plumb, Engineering Manager

A handwritten signature in cursive script, appearing to read 'E Plumb', is written in black ink.

Signed at Wrexham, Date

October 2015

<b>CHIPPER</b>
----------------

**INDEX**

<b>GUARANTEE.....</b>	<b>1</b>
<b>DELIVERY .....</b>	<b>1</b>
<b>SAMPLE RATING LABEL.....</b>	<b>1</b>
<b>INTRODUCTION.....</b>	<b>2</b>
<b>CHIPPER DIMENSIONS.....</b>	<b>2</b>
<b>INSTALLATION .....</b>	<b>3</b>
<b>ELECTRICITY SUPPLY CONNECTION.....</b>	<b>3</b>
<b>COMMISSIONING .....</b>	<b>4</b>
<b>OPERATION.....</b>	<b>4</b>
<b>CHANGE CHIP SIZES .....</b>	<b>5</b>
<b>CLEANING.....</b>	<b>5</b>
<b>MAINTENANCE.....</b>	<b>6</b>
<b>ORDERING SPARE PARTS.....</b>	<b>6</b>
<b>WIRING DIAGRAM FOR CHIPPER.....</b>	<b>7</b>
<b>EXPLODED VIEW .....</b>	<b>8</b>
<b>PARTS LIST .....</b>	<b>10</b>

## GUARANTEE

This equipment is guaranteed by IMC for 2 years from the date of its purchase from IMC, or from one of its stockists, dealers or distributors. The guarantee is limited to the replacement of faulty parts or products and excludes any consequential loss or expense incurred by purchasers. Defects which arise from faulty installation, inadequate maintenance, incorrect use, connection to the wrong electricity supply or fair wear and tear are not covered by the guarantee.

Please observe these instructions carefully.

The guarantee applies in this form to installations within the United Kingdom.

## DELIVERY



The packaged machine consists of:

Chipper Unit	1
Instruction Booklet	1
Wall Plaque	1
Guarantee / Registration Card	1

Please notify both the carrier and the supplier within three days of receipt if anything is missing or damaged.

Check that the correct machine has been supplied and that the voltage, marked on the rating plate, is suitable for the supply available. The rating plate is located on the right hand side of the case.

## SAMPLE RATING LABEL

		IMPERIAL MACHINE COMPANY Ltd LL13 9RF, UNITED KINGDOM TEL +44 (0)1978 661155		 	
POTATO CHIPPER		FREQUENCY(Hz)	50	www.imco.co.uk	
TYPE / MODEL	PC2	IP RATING	IP55		
VOLTAGE RANGE	230	dB (A)	56		
PHASE	1	AMPS (MAX)	2.4		
SERIES #	4	kW (MAX)	0.34		
SERIAL NUMBER = 6111110001					

## INTRODUCTION

The Chipper is intended for cutting peeled potatoes into chips or scallops, in a batch process.

## CHIPPER DIMENSIONS

All dimensions are in mm.

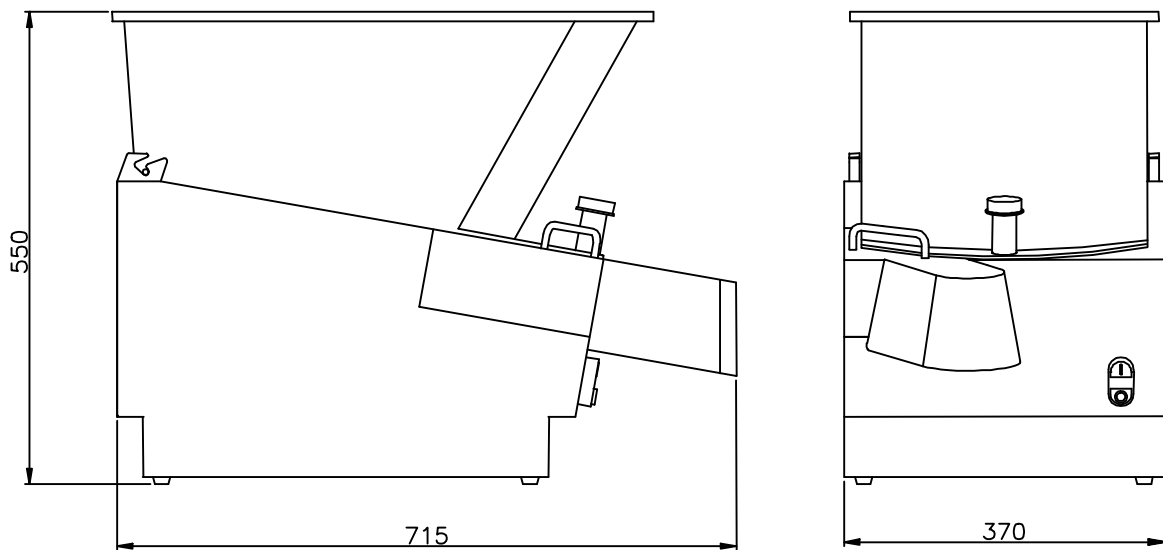

## INSTALLATION

### For the Installer:

These Instructions contain important information designed to help the user obtain the maximum benefit from the investment in an IMC Chipper. Please read them carefully before starting work, and consult with the supplier in the event of any queries.

Be sure to leave this Instruction Manual with the user after installation of the machine is complete.

### Procedure

The unit is designed to stand on a bench, table, or on a draining board. Ensure that whatever is used for this purpose is sturdy and rigid and not more than 750 mm high. A higher table makes it difficult to load the machine.

The Chipper should be placed where supplies of peeled potatoes from the peeling machine are readily accessible, after which the output of chips need to be in easy reach of the fryer.

The IMC Chipper has a top loading hopper into which potatoes can be tipped from either side or from the front. It is not handed, and no consideration need be given to its loading direction. The discharge of chips is from the chute at the front of the machine, and the machine should be placed so that this chute is directly over the receiving container.

## ELECTRICITY SUPPLY CONNECTION

A Wiring Diagram is shown on Page 7.

Position the Chipper in the chosen site. The electricity supply connection should be made to a power outlet socket or isolator mounted on the wall close to the machine. This socket or isolator must be accessible once the machine is installed. Before connecting, check that the voltage shown on the rating is correct for the electricity supply you have available. The outlet should be fused at 13 amps.

**NOTE: The plug is fitted with a 10amp fuse.**

**WARNING: This machine must be earthed**

Should the supply cord become damaged then an approved electrician must fit a replacement. The IEE Codes of Practice must be observed.

An equipotent bonding terminal is provided at the back of the unit near the cable outlet for external earth bonding. Provision of an earth bond does not remove the requirement for an earth in the electrical supply.

## COMMISSIONING

Open the hopper by fully unscrewing the interlock knob at the front and lifting up until the hopper is fully resting back on its hinges. Turn the rotor by hand to ensure that it is completely free to rotate and that the knife block assembly is properly in position. Replace the hopper and screw down the interlock knob until it is tight.

It is now safe to switch on at the wall socket and to start the machine by pressing the start button on the front of the machine (green button). To stop the machine press the red button.

One of the safety features provided on the IMC Chipper are the interlock devices that ensures that the machine cannot run unless both the knife block and the hopper are properly and fully in position. This makes it impossible for the operator to touch the spinning rotor whilst it is running.

To confirm that the interlock is operating correctly press the start button to switch the machine on. Then whilst it is still running, unscrew the hopper interlock knob. After two or three turns the machine should switch off, but there are still two or three further turns of the knob necessary before the hopper can be opened. The rotor should be stationary within 2 seconds of the hopper being opened. If the knife block is not in place, another interlock will prevent the machine from running.

## OPERATION

With the machine running, feed peeled potatoes into the hopper. It will hold approximately 12kg of potatoes, which self feed into the mechanism of the machine and discharge as cut chips from the chute.

Some care is necessary when loading, as the rotor will not accept abnormally large potatoes, so these must be cut into two. The hopper is specially designed not to pass potatoes which are over size and which could otherwise clog the mechanism. It is also essential that only potatoes be fed in to this machine.

**NOTE: take great care to ensure that there are no stones mixed in with the potatoes.**

A stone or any other foreign object will damage the cutting knives and could cause the machine to jam. In this event the machine has an inbuilt protection device, which will switch it off before the electric motor burns out. This overload protection feature will automatically reset itself when it cools down but it is necessary to wait a few minutes for this to happen. After clearing the jam resume operation by pressing the start button. Should a stone damage the knife blades they must be replaced as further use could break the blades.

This Chipper is designed for batch process work; switch the machine off once all the potatoes have been cut. The motor is fitted with a thermal trip that will stop the machine if the motor overheats. This protection feature will automatically reset itself when it cools down but it is necessary to wait a few minutes for this to happen.

The machine will switch itself off in the event of failure of the electricity supply whilst operating. When the supply is restored the machine must again be switched on. It is fitted with no-volt release.

### CHANGE CHIP SIZES

To change to a different size of chip, change the knife block assembly. Spare knife block assemblies are available from IMC. Open the hopper, lift out the knife block and replace with the alternative selected. Knife blocks are available in the following sizes from the standard range: 8mm, 11mm, 14mm and 14x17mm. Scallops can be cut with similar knife block assemblies. The standard scallop size is 8mm.

### CLEANING

It is essential to clean the machine at least once a day, preferably at the end of each period of operation.

1. Switch off at the socket or isolator
2. Fully unscrew the interlock knob, open the hopper and lift it out of its hinge seating at the back
3. Clean the hopper in a sink, dishwasher, pot wash or by hosing with a spray
4. Remove the knife block by lifting upwards, off its locating dowels  
**NOTE: Take care when handling the knife block. The blades are sharp.**
5. Clean the knife block under a spray or running tap and remove any residual pieces of potato. **DO NOT use any metallic objects**, such as a knife or screwdriver, to un-block the knife block. Visually inspect all blades for wear or damage, and replace the knife pack as necessary. Do not attempt to straighten a bent blade - bent blades should be replaced immediately.
6. Lift the rotor carefully off its spindle.
7. Clean the rotor in a sink, pot wash, etc.
8. Clean out the interior of the base unit and wipe over the exterior with a damp soft cloth. Do not hose down the exterior of the machine.  
**DO NOT USE CLEANING MATERIALS CONTAINING ABRASIVES OR BLEACHES.**
9. Reassemble the machine, reversing the above disassembly procedure. When replacing the rotor, ensure that it is put back square on its spindle. Make sure that it is properly seated on its cross pin by turning it slowly until it drops onto this seating. When replacing the knife block it should slip down easily on to its dowel pins, make certain that it is fully down.

## CHANGING KNIFE BLADES

The knife blades are supplied as a pack and individual blades cannot be changed. Change the knife blade pack as soon as it is damaged or blunt. To change the knife blade pack remove the knife block and undo the two screws securing the knife blade pack. Dispose of the old blades carefully and screw the new knife blade pack in place. See diagram below.

For optimum performance IMC recommend changing the blade pack every 6 months, or sooner depending on usage.

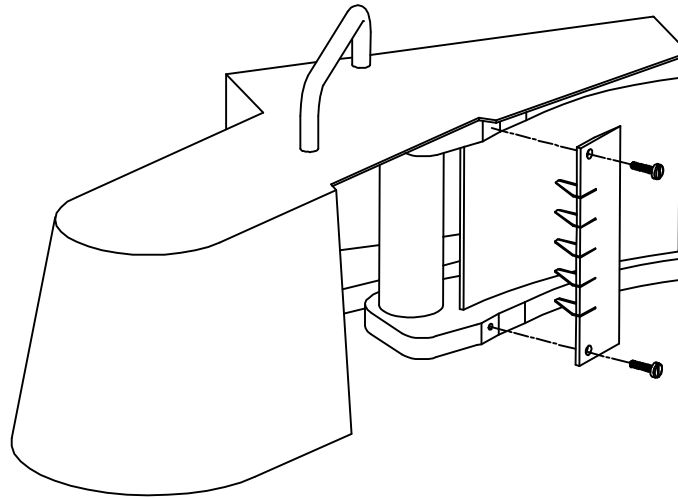

**NOTE: Take care when handling the knife block. The blades are sharp.**

## MAINTENANCE

Details of IMC Service Contracts are available on application.

## ORDERING SPARE PARTS

In the event that spare parts or accessories need to be ordered, please always quote the SERIES AND SERIAL NUMBER of the machine. This is to be found on the rating plate located near the supply cable.

For installations outside the UK please contact your supplier.

For information on IMC spares and service support (if applicable), please call IMC on +44 (0)1978 661155. Alternatively, contact us via email or fax:

IMC Service Desk

Fax: +44 (0)1978 667766

E-mail: [service@imco.co.uk](mailto:service@imco.co.uk)

IMC Spares Desk

Fax: +44 (0)1978 667759

E-mail: [spares@imco.co.uk](mailto:spares@imco.co.uk)

WIRING DIAGRAM FOR CHIPPER

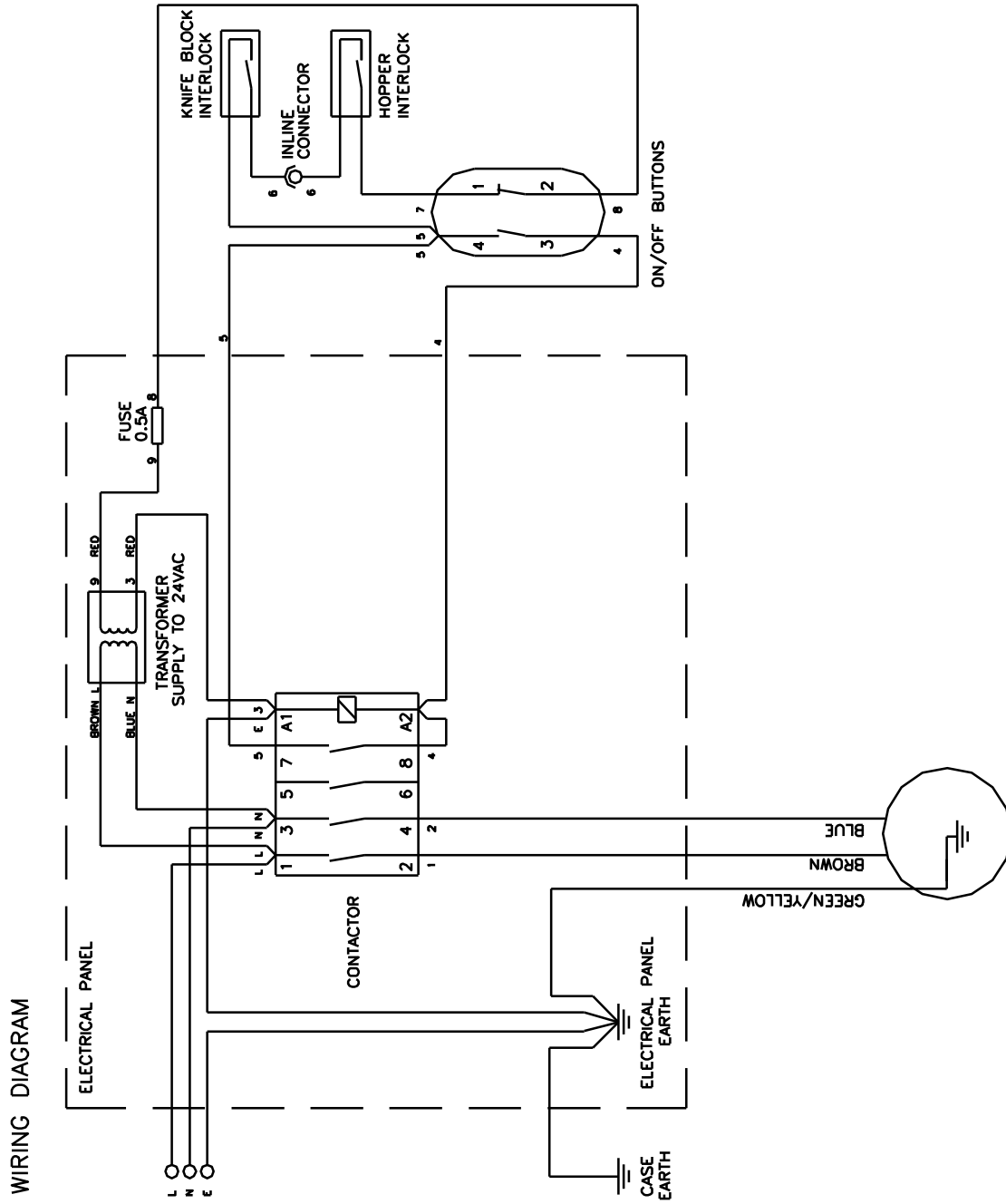

EXPLODED VIEW

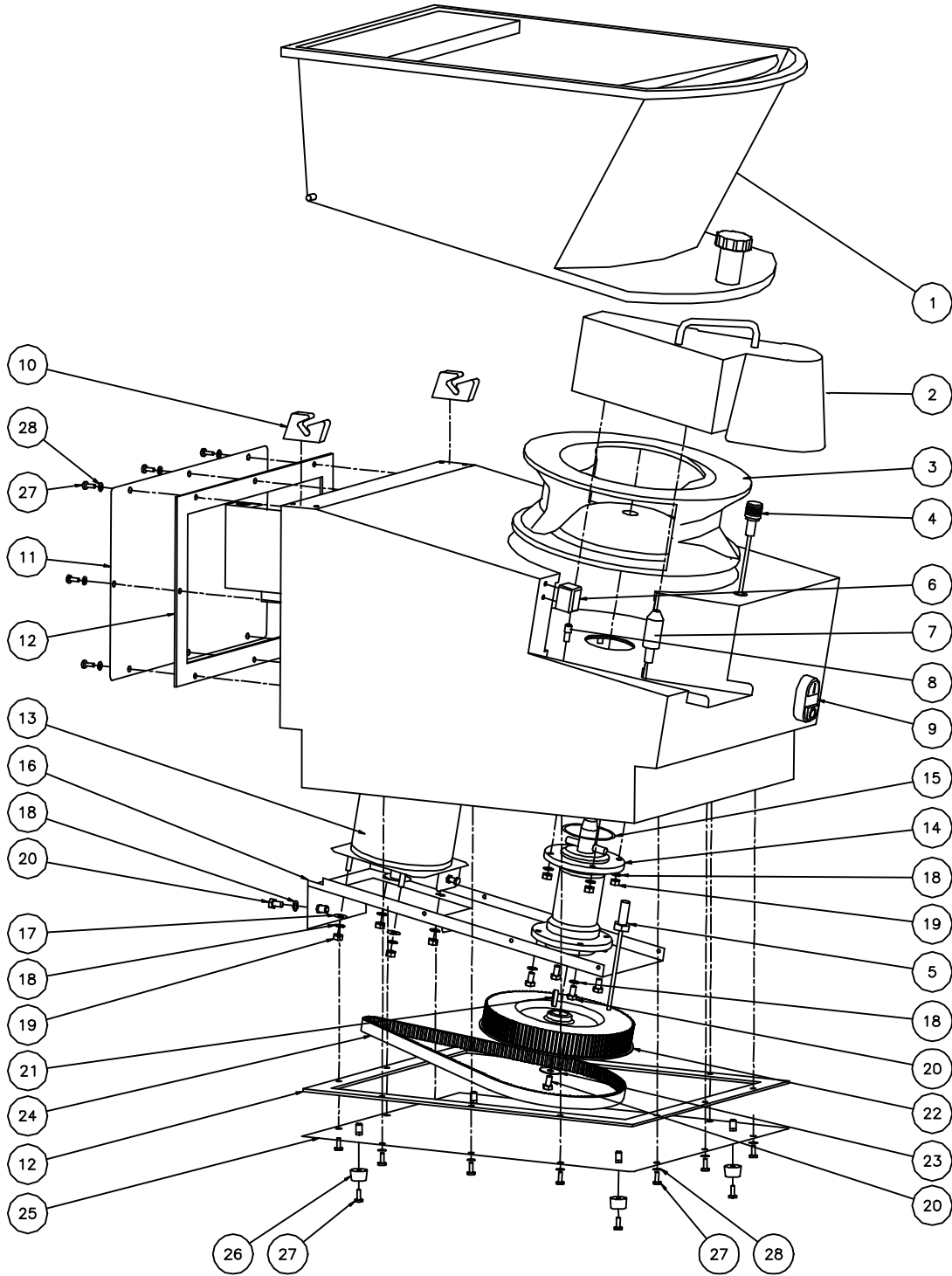



**PARTS LIST**

ITEM	PART NO	DESCRIPTION	ITEM	PART NO	DESCRIPTION
1	S61/121	Hopper assembly	11h	G30/343	Contactora 24V ac
	M81A	Interlock body	11i	G60/427	Transformer terminated
	A12/011	Interlock spring	11m	D25/033	M4 Shakeproof washer SS
	M69	Interlock knob	11n	D20/011	M4 Full nut SS
	D26/017	Interlock pin	11o	D25/004	M5 Shakeproof washer SS
	M48	Interlock knob cap	11p	D20/038	M5 Full nut SS
2	S61/111	8mm Scallop knife block	11q	D25/062	M8 Lock washer SS
	S61/114	14mm Knife block	11r	D20/014	M8 Full nut SS
	S61/115	14x17mm Knife block	12	K08/043	Gasket strip
	S61/129	Knife blade pack 14mm	13	S61/177	Motor assembly
	S61/128	Knife blade pack 17mm	13a	E61/014	Motor mounting plate
	L61/004	Scallop slicing blade	13b	D19/032	M5x12 Hex screw SS
	D22/060	No 6 Self tapping screw SS	13c	D19/115	M6x30 Hex screw SS
	C61/002 M1 Z	Rotor	13d	D20/013	M6 Full nut SS
	S61/123	Hopper switch assembly	13e	A06/099	Drive pulley (keyed)
	S61/127	Knife block switch assy	13f	L61/041	Bush (for drive pulley)
	L61/013	Anti deflection block	13g	D19/142	M4x25 Hex screw SS
3	D25/004	M5 shakeproof washer SS	13h	G60/323	Motor Cable Assy
4	D19/032	M5x12 Hex Screw SS	14	S61/118	Bearing housing assembly
5	L61/009	Knife block locating pin	15	A02/068	O . Ring
6	D25/003	M10 spring washer SS	16	E61/015	Drive plate
	D20/015	M10 full nut SS	17	D25/052	M6 Plain washer SS
	L34/005	Knife block short pin	18	D25/005	M6 Shakeproof washer SS
7	D25/052	M6 Plain washer SS	19	D20/013	M6 Full nut SS
	D20/013	M6 Full nut SS	20	D19/038	M6x12 Hex screw SS
	G45/109	On / off button	21	D27/031	Drive key
8	G45/110	Button protective boot	22	A06/090	Driven pulley 114-5M-25
	G45/111	Button contacts NO & NC	23	D25/019	M6 25OD plain washer
	A13/024	Hopper hinge	24	A05/041	Drive belt 850 - 5M - 25
9	D25/033	M4 Shakeproof washer SS	25	E61/007	Base plate
	D19/120	M4x8 Hex screw SS	26	A13/108	Plastic foot
	S61/172	Rear panel assembly	27	D21/044	M5x12 Pan screw SS
10	E61/033	Rear panel	28	D25/004	M5 shakeproof washer SS
	G60/101 M4	Mains cable with plug			
	A10/266	Strain relief gland			
11	A10/224	Back nut			
11a	G35/012	Fuse holder			
11b	G35/004	Fuse 5x20 0.5A			
11c					
11d					
11e					
11f					

**Note**

The parts list is for 230V 1ph 50Hz machines. For electrical parts for other voltages please contact our spares department.