

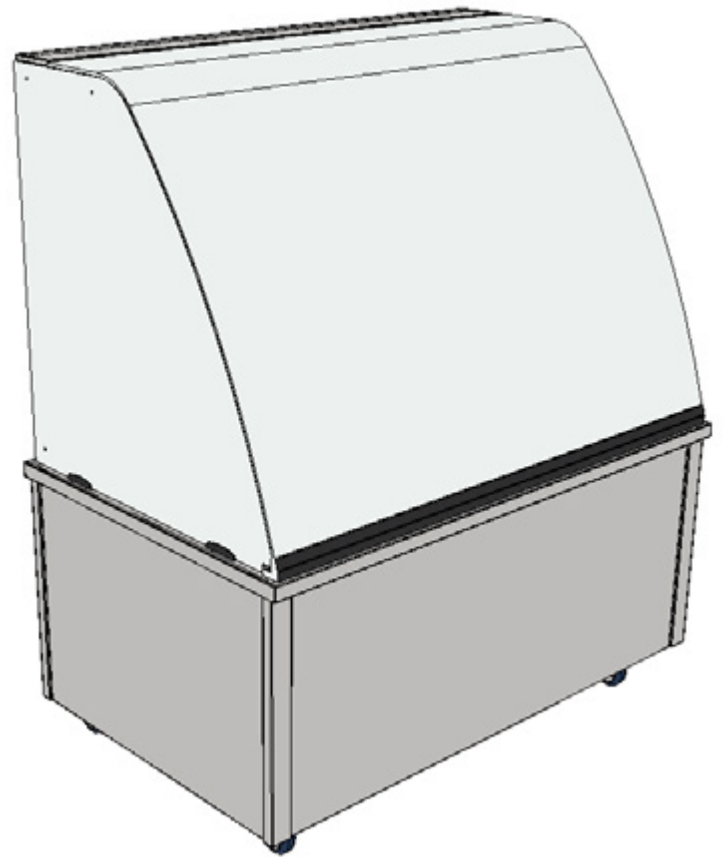

Patisserie

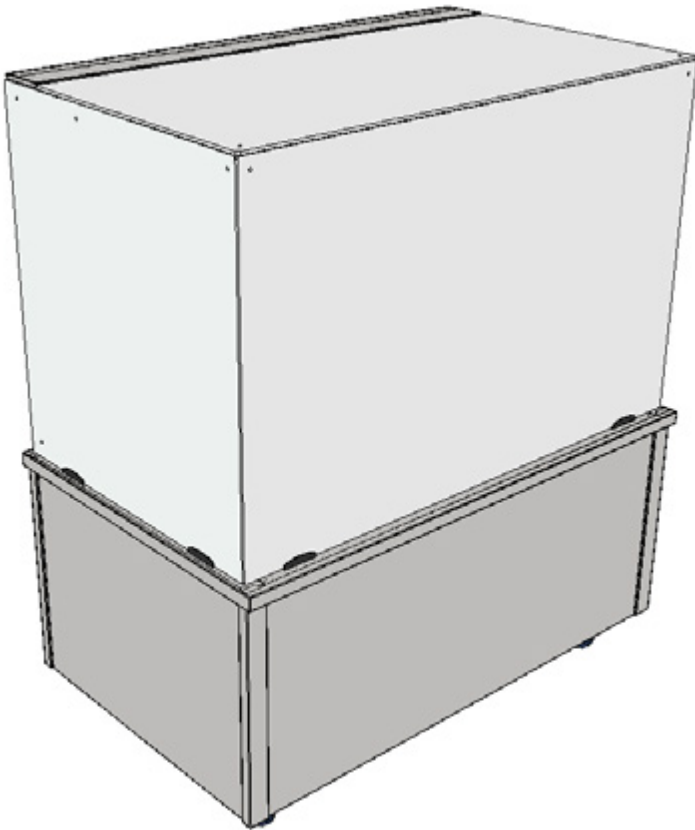

Operating & Service Manual





To ensure the best results from this unit please take the time to read and follow all safety, installation and maintenance guidelines carefully before proceeding to install. Keep this manual in a safe place for future consultation.



These appliances are marked in compliance with the relevant Low Voltage & EMC Directives. Voltage stated on unit data plate.



Warning! Please pay attention to sections of the manual displaying this symbol.



Warning! Do not attempt to use a hose or water jet to clean this unit. For cleaning instructions, refer to section 15.



Warning! Depending on your unit model, this unit's system may be charged with a flammable refrigerant (R290).

The appliance must only be used for the purpose it was designed for and may become unsafe if used for any other purpose. Operators should be trained. The room where this trolley is used must be dry, clean with temperatures between 16°C and 25°C and with a maximum relative humidity of 60%. This unit is for indoor use only and has an IPX4 rating.

Contents

		page
1	Electrical Specification	4
2	General Installation	5
3	Refrigerated Display <i>Specification & Installation conditions</i>	6 / 7
4	Refrigerated Display <i>Operation</i>	8
5	Heated Display <i>Specification</i>	9
6	Heated Display <i>Operation</i>	9 / 10
7	Cleaning	11

1: Electrical Specification



This appliance must be earthed and damaged cables must be replaced by a suitably qualified person!

	1 Phase Cable	3 Phase Cable
Live (L1)	<i>Brown</i>	<i>Brown</i>
L2	<i>X</i>	<i>Black</i>
L3	<i>X</i>	<i>Grey</i>
Neutral	<i>Blue</i>	<i>Blue</i>
Earth	<i>Yellow & Green (Striped)</i>	<i>Yellow & Green (Striped)</i>



A mains cable, type H07RN-F, conforming to code designation 60245 IEC 57, is supplied.

“If the supply cord is damaged, it must be replaced by the manufacturer, service agent or suitably qualified person”

Appliance must be disconnected from the power supply during cleaning, maintenance and part-replacement”.

2: General Installation

Before installation please read the following points:

- *When placing the units in position ensure there is adequate access.*
- *These mobile units can simply be butted up together to form a food service counter.*
- *Roll into position and apply the brakes on the operator's side.*
- *Before installing, it is recommended that the floor is swept clean.*



This equipment is designed to be operated by suitably qualified persons. It is the responsibility of the Supervisor or equivalent to instruct users, provide suitable P.P.E., Show the mains isolating switch location, and inform users that parts may become hot, causing injury if touched.

1. *Remove all packaging & plastic coatings from the appliance.*
2. *Check for any damage.*
3. *Assemble all parts, including shelves, food containers etc.*
4. *Ensure all switches and thermostat controls are in the OFF position.*
5. *Connect the mains input plug to the socket outlet.*
6. *Turn on and check the unit is functioning correctly.*

3: Refrigeration models specification

Model	Weight (kg)	Dimensions L X W X H (mm)	Electrical Supply	Power Rating (kw)
PAT2C	121	900 x 750 x 1400	13amp	1.5
PAT2CSL	129	1200 x 750 x 1400	13amp	1.5
PAT3C	184	900 x 750 x 1400	13amp	1.5
PAT3CSL	192	1200 x 750 x 1400	13amp	1.5



This unit's system is charged with a flammable refrigerant (R290).



Before commencing there are certain environmental parameters that must be followed please read the additional installation conditions on page 6 & 7.)

4: Refrigeration installation conditions

Refrigerated Unit Venting

When installing these refrigerated units, allowances must be made for air venting.

It is crucial that there is an unrestricted air flow through the under slung compressor and condensing coil. Proper venting must be provided ensuring cool air from the room can be pumped in through the condensing coil and out the other side.

The hot air blown out from the opposite side 'must not' be allowed to be sucked back through.

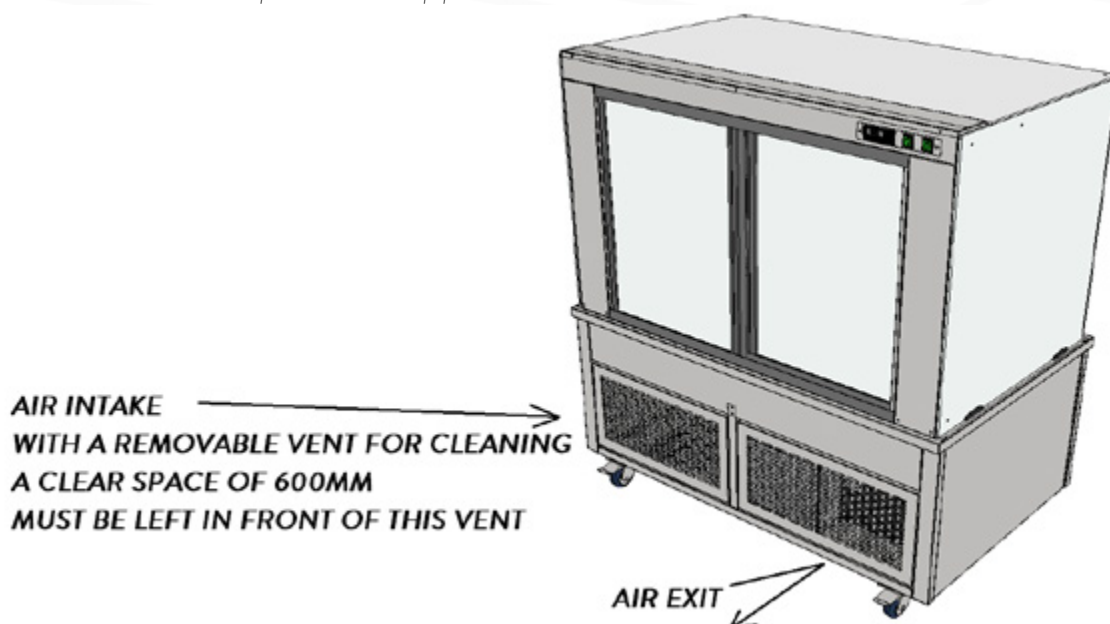

Blocked vents will cause reduced efficiency and lead to malfunction

3: Refrigeration installation conditions



To ensure the satisfactory operation and optimum efficiency of this unit, it is imperative that the ambient room conditions where the units are being used do not exceed a room temperature of 25°C or exceed a relative room humidity of 60%.

Should conditions exceed the above, the display units may not maintain food temperatures at the required levels.

E & R Moffat cannot accept responsibility for the performance of the units being used in extreme conditions.



Do not install units where there is high radiated heat, e.g. direct sunlight, room heaters, or bright spot lights. Do not install units in draughty conditions where the air movement is greater than 0.2mtr/sec. (e.g. near doors, windows, air conditioning units or fans]

The condensing coil & vents requires regular cleaning to maintain the performance of the unit, as air borne particles will choke the coils fins. They should be cleaned with a soft brush and vacuum.

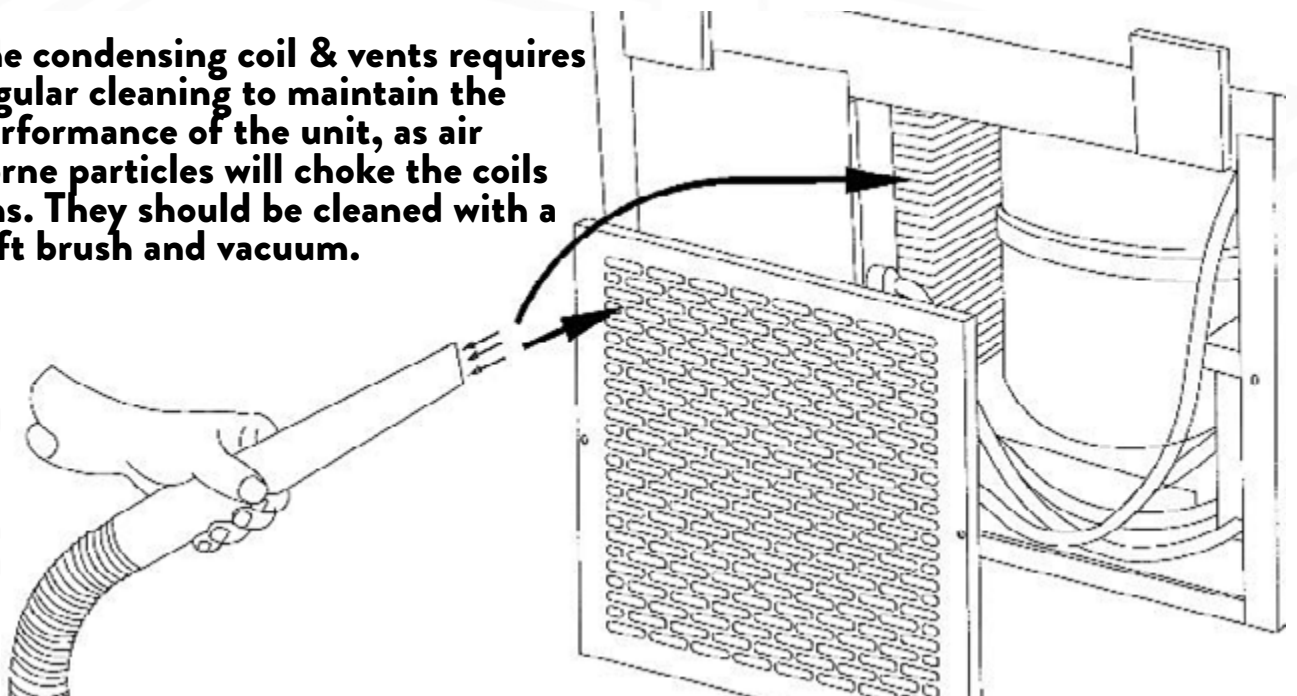

These units require good airflow inside and outside. It is essential the vents in the external panels do not become blocked as this can cause the unit to fail, due to overheating. Internally good air flow must also be maintained, a small space should be left between all products.

4: Refrigeration model operation

Refrigerated display units are designed to keep pre-chilled food at a regulated serving temperature and are suitable for the display of most types of cold food. Designed to provide a gentle flow of cold air maintaining a safe and compliant temperature within. The Chilled display has an automatic defrost, and automatic condensate water evaporation system, eliminating the need to manually empty drip trays or on-site drainage.

 **The controlled air temperature is factory set to operate between 2° and 5°.**

The Display unit is controlled by a green neon on/off switch and a digital control.

- Connect plug to 13-Amp socket and switch on at mains socket.
- Power on with green illuminated Switch
- Digital illuminates and controls the display temperature
- Allow 30mins for the display too cool down before loading product
- The controlled air temperature is factory set to operate between 2° and 5°
- Defrost is factory set to operate automatically when required
- When serving is complete all switches should be turned off.



 **To enable automatic defrost, the 13A plug must be constantly switched on. The green switch can be switched off when the cooling is no longer required, however, do not unplug the unit from the mains power.**



**Product should already be 5° or below before loaded into the display
These units are not designed to chill down hot food**

8: Heated models specification

Model	Weight (kg)	Dimensions L X W X H (mm)	Electrical Supply	Power Rating (kw)
PAT2H	105	900 x 750 x 1400	13amp	1.70
PAT2HSL	111	1200 x 750 x 1400	13amp	1.70
PAT3H	150	900 x 750 x 1400	13amp	2.15
PAT3HSL	158	1200 x 750 x 1400	13amp	2.15

Designed to keep pre-cooked food at serving temperature and are suitable for the display of most types of hot foods. Three anodised alloy heated shelves for holding warm products and a non heated bottom deck for croissants etc.

Complete with hinged rear glass doors.



These units are not designed to heat up cold food.

9: Heated models operation

The correct serving temperature is dependent on the food type, quantity and packaging, etc. The Display unit is controlled by a green neon on/off switch and a digital temperature control.

- Connect plug to 13-Amp socket and switch on at mains socket.
- Power on with green illuminated Switch
- Digital illuminates and controls the display temperature
- Leave for 30mins to reach serving temperature
- Set the temperature of the display to the desired position
(Factory set at 85° adjustable between 65° and 110°)
- Precooked food can now be loaded.
- When serving is complete all switches should be turned off.
- To maintain the life clean regularly with a damp cloth.



These units will remain hot for a long period of time after use

9: Heated models operation

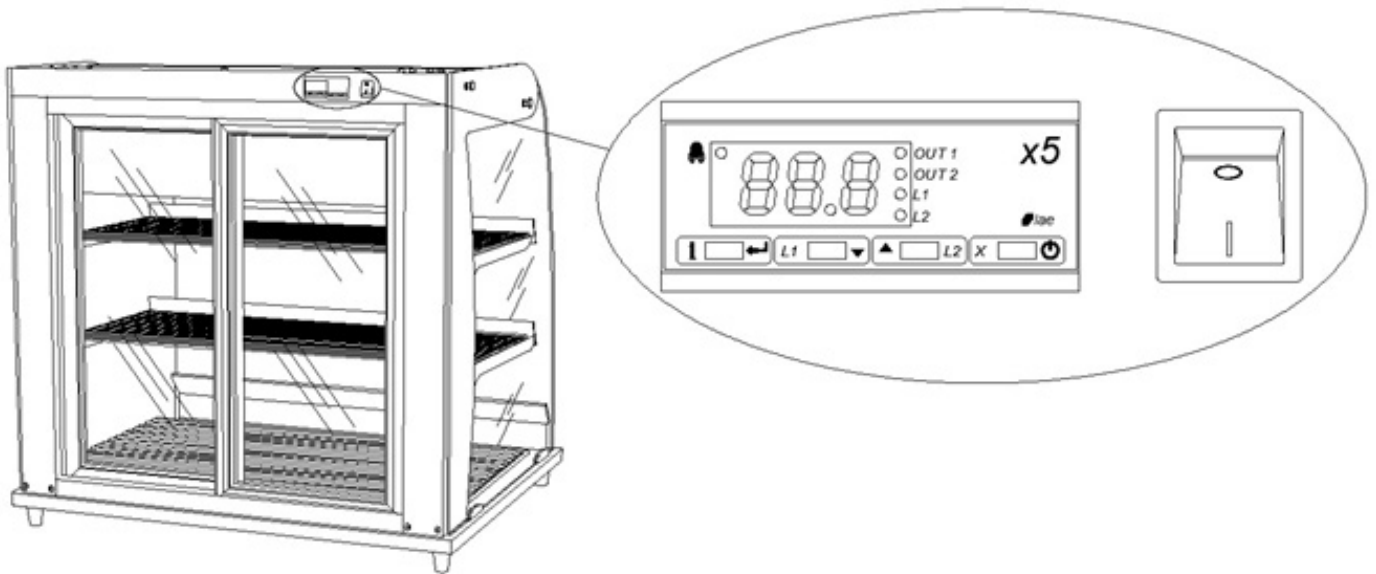

How to Change the Temperature Setting

To access the temperature in the controller,

- Press the **L1** key. The display will show **1SP** for 1 second and then the current temperature it is set for
- Use the **L1** and **L2** keys to adjust the temperature
- **L1** for a lower or **L2** for a higher temperature
- To save the temperature. Press the **i** key or wait 10 seconds
- To exit without changing the setting, press the **X** key.

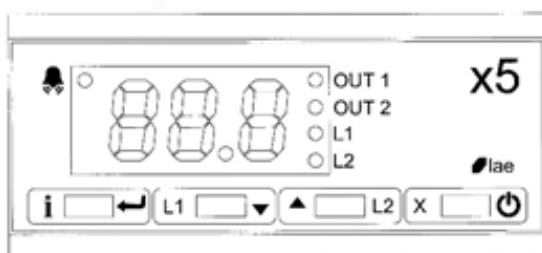

10: Cleaning



Before attempting to clean the unit, please ensure that the Unit is isolated from the electric supply and allowed to cool down, with all food plates and other Dishes removed from the unit.

Do not use a water jet or pressure spray to clean this appliance.

1. *Disconnect trolley from mains and wait until appliance has cooled.*
2. *Wipe clean using hot, soapy water and soft, non-abrasive cloth. Ensure that the stainless steel is wiped in straight strokes following the grain of the material.*
3. *Wipe dry using a clean cloth. Do not use scouring pads or abrasive cleaners of any type. Shelving and select inner panels can be removed to allow a deeper internal clean. Ensure all panels and fixings are replaced after cleaning operation.*
4. *Refrigeration compartment should be washed and then dried with a cloth after each service.*
5. *The chilled well has removable base sections for easy cleaning and maintenance. They should be removed periodically and the area beneath wiped clean.*
6. *The drain holes must also be kept clear from blockage.*
7. *Wipe down sneeze screen and glass top with a damp, clean cloth.*
8. *Finish by carefully drying with a soft dry cloth or Kitchen Towels.*



Do not use scouring pads or abrasive cleaners of any type.

Do not use Solvents, bleach, Caustic Cleaners or biological powders on any surface.



Special care should be taken around electrical parts, avoided excessive use of water.

Take special care when cleaning glass use a soft duster & glass cleaner spray.

Thank you for choosing E&R Moffat!

*Scan the QR code below to visit the
E&R Moffat website for further information:*

