

**FLEXI+SERVE**



## FS-AW Range

Available as:  
FS-AW2, FS-AW3, FS-AW4, FS-AW5  
Including Gantry versions & 800mm Height



British Built for Purpose.





# Welcome to Parry

Parry is one of the UK's foremost manufacturers of high-quality Stainless Steel Fabricated Products with a 40-year heritage rooted in British craftsmanship.

At Parry, quality and service are second nature. Striving to exceed our customers' expectations is not just our motto; it's the very heartbeat of our business. Our commitment to our customers is reflected in the **Parry 4E Standard Inspection Body** stating that all our products are:



**Easy to use**



**Easy to maintain**



**Easy to clean**



**Easy to repair**

Our ranges of Stainless Steel Products have been specifically designed with the consumer in mind and are tailored and compliant to your specific industry sector. All our products are 4E Compliant and meet EU & UK regulations, where applicable. The Parry brand stands for quality, reliability and value.

Our British designed products have been created by our expert in-house development team and manufactured to exacting standards using Industry specified grade of European stainless steel and holding relevant EU & UK certification for all product.

ISO9001 certification and continual investment in the training and development of our highly skilled, artisan workforce means that our clients have genuine peace of mind that they are buying hand crafted, quality products supported by five-star customer service. All Parry products meet EU regulations for their respective sector.

We are LEAN manufacturers, minimising waste, maximising productivity. We are proud to run an operation that is committed to minimising our impact on the environment.

Our equipment and furniture are manufactured in our 45,000 sq ft manufacturing facility in Draycott, Derbyshire in England's industrial heartland. Products are made to order if not available in our stocked items which means you can choose from 600 products, offering over 3,500 variants, with short lead times to suit your specific needs. That means you get exactly what you need when you need it.

Our product information can be found here, in our brochure or on our website [www.parry.co.uk](http://www.parry.co.uk).

You have my personal commitment that Parry will exceed your expectations. Should you have any questions please contact your distributor. Alternatively, our customer services team will be happy to help you on **01332 875544**.

**Mark Banton MBA**  
**Managing Director**



Contents.....	1
Product Overview .....	2-4
Safety Instructions .....	5
Installation Instructions .....	5
Operating Instructions .....	10
Cleaning Instructions .....	11
Maintenance Instructions.....	11
Fault Finding .....	12
Service Information.....	12
Wiring Diagram .....	13
Exploded View .....	14
Parts List .....	15-16
Warranty Information.....	17
Disposal & Recycling .....	18

Parry Catering Equipment (Midlands) Ltd, Town End Road, Draycott, Derby, DE72 3PT.  
Sales Tel: 01332 875544



## Product Overview

---

The new Parry Flexi-Serve range has been designed specifically to suit the requirements of the user. The FS-AW Range is designed to provide chilling to GN containers using eutectic plates in an insulated well.

The Flexi-Serve range can be manufactured with or without a gantry.

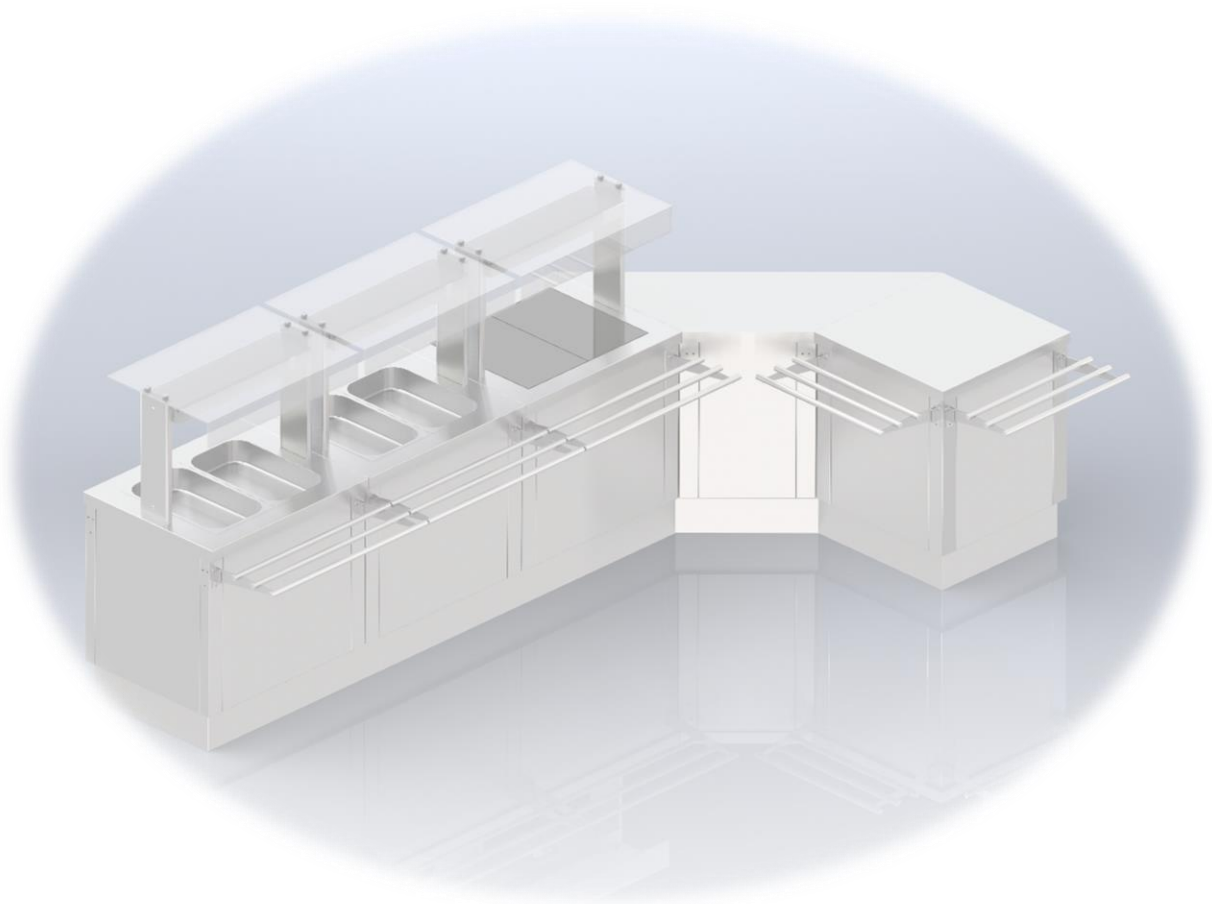

It leads the industry in:

- Design and aesthetic appeal
- Performance
- Power
- Functionality
- After sales support

**900mm Height Range (Standard)**

Features	FS-AW2	FS-AW3	FS-AW4	FS-AW5
External Dimensions (mm)	860(w)	1160(w)	1495(w)	1830(w)
	700(d) x 900 (h)			
Internal Cupboard (mm)	705(w)	1005(w)	1340(w)	1675(w)
	580 (d) x 410 (h)			
Shelves	2 Layers supplied 4 Positions			
Height with Gantry (mm) <b>Optional</b>	1455 (h)			
No. of 1/1 GN compartments	2	3	4	5
Total Power (Watts)	N/A	N/A	N/A	N/A
Total Power with Gantry (Watts)	10	20	20	30
Voltage	230V 50Hz ~			
Weight (kg)	86	108	128.5	169.5
Weight with Gantry (kg)	108	137	176	226.5

**800mm Height Range**

Features	FS-AW2-8	FS-AW3-8	FS-AW4-8	FS-AW5-8
External Dimensions (mm)	860(w)	1160(w)	1495(w)	1830(w)
	700(d) x 800 (h)			
Internal Cupboard (mm)	705(w)	1005(w)	1340(w)	1675(w)
	580 (d) x 310 (h)			
Shelves	2 Layers supplied 3 Positions			
Height with Gantry (mm) <i>Optional</i>	1355 (h)			
No. of 1/1 GN compartments	2	3	4	5
Total Power (Watts)	N/A	N/A	N/A	N/A
Total Power with Gantry (Watts)	10	20	20	30
Voltage	230V 50Hz ~			
Weight (kg)	76.5	93	113	149.5
Weight with Gantry (kg)	96.5	122	157	202









## Safety Instructions

---

The unit has been designed to easily be moved into position and has four braked castors to lock in position to avoid movement whilst in operation. Alternatively, the units can be supplied on adjustable legs for fixed position.

This appliance has been designed to warm products and therefore during its use parts of the appliance will become very hot. All personnel must be given adequate supervision and training in the safe use of this appliance.

-  All appliances other than those fitted with a sealed moulded plug must be fitted with a sealed moulded plug and must be fitted by a qualified electrician, in accordance with current regulations.
-  The unit should be installed in compliance with the Installation Instructions and the National regulations in force at the time. Particular attention should be paid to the Health and Safety at Work Act.
-  To prevent shocks, all appliances whether gas or electric, must be earthed.
-  To avoid scratching the highly polished exterior surface of this equipment whilst in transit, the protective film on the exterior surfaces has NOT been removed.
-  It is IMPORTANT that this protective film is peeled off before the equipment is used.
-  Ensure that vents intended to provide air flow in and around the unit are not obstructed.
-  Ensure the appliance is isolated from the power supply before installing, cleaning or maintaining the appliance





## Installation Instructions



---

The unit has been designed to easily be moved into position and has four braked castors to lock in position to avoid movement whilst in operation. Alternatively, the units can be supplied on adjustable legs for fixed position.

### Mobile Use

-  Position the Flexi-Serve unit in the serving position and secure in place using the 4 braked castors.
-  Units fitted with 13amp plug, plug into a suitable socket.

### Static Use

-  Position the Flexi-Serve unit in the serving position and adjust legs to suit the surface.
-  Units fitted with 13amp plug, plug into a suitable socket.

**Taking Out the Doors**

Slide door to the middle

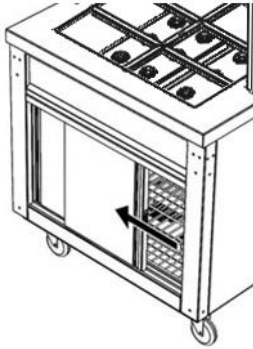

Lift door up

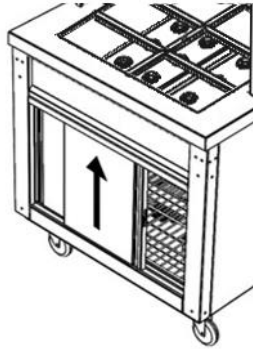

Angle bottom of door forward

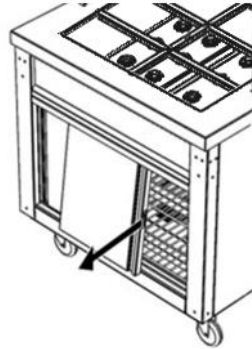

Pull door down

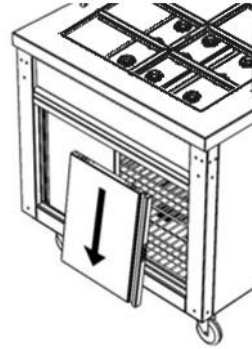

**Attaching the Tray Slide onto the Unit**

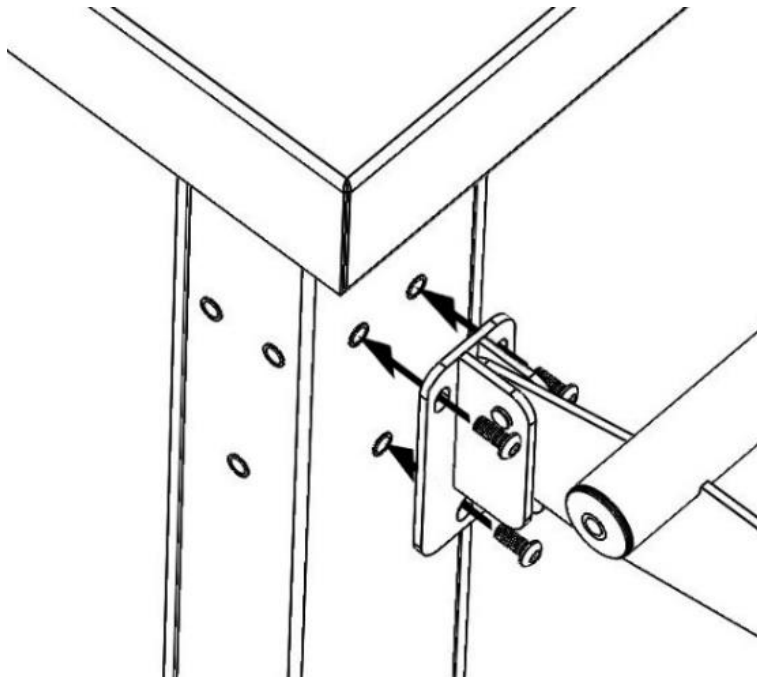

### Removing the Side and Front Panels

Unscrew the screw from the bottom of the unit with the supplied Allen Key.

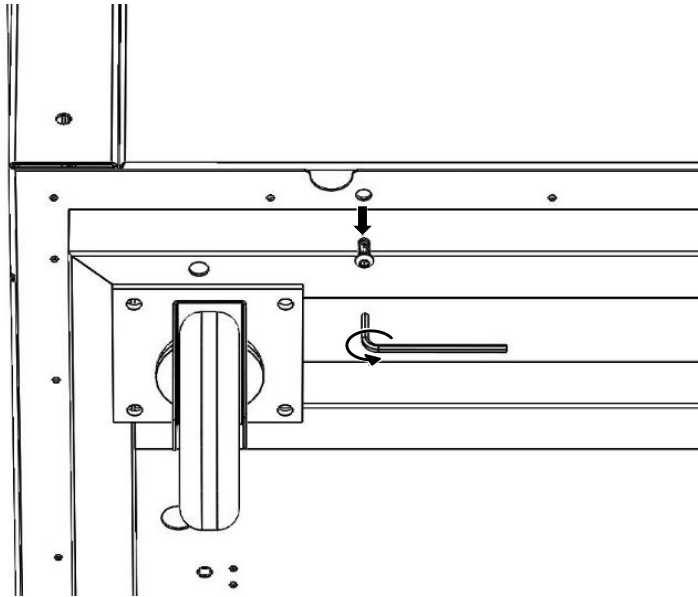

Using the finger cutouts on the bottom of the unit pull the panel out and then slide down.

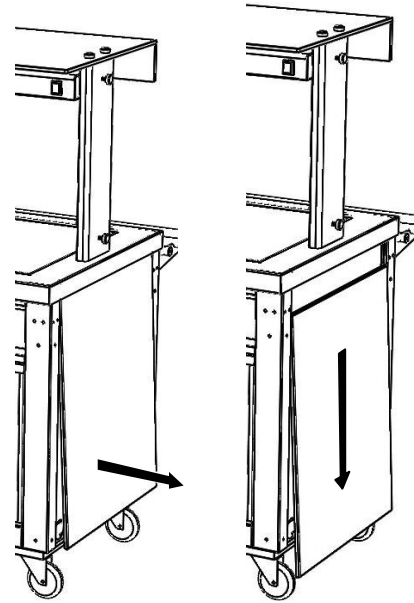

### Fixing the Connecting Plates and Trims to the Units

Push the two units together that you require the joining plate to be attached to. Screw in the supplied Allen screws with the supplied Allen key.

Top of Unit

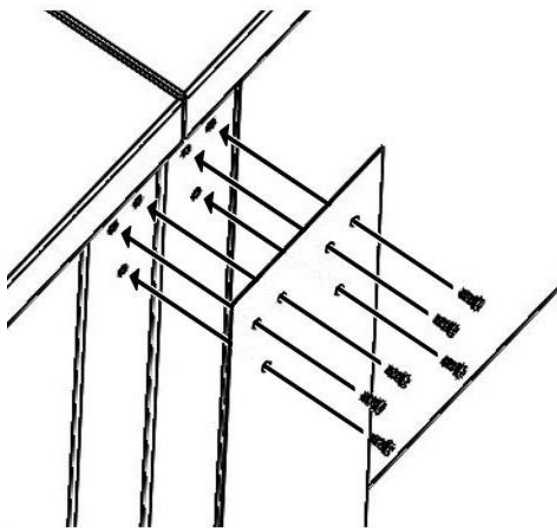

Bottom of Unit

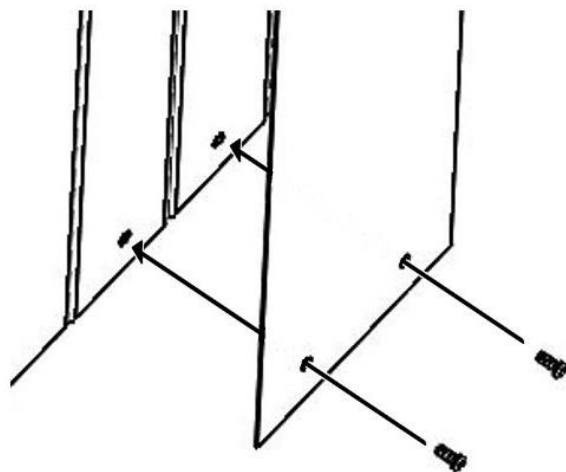

### Kick Plate Installation (If fitted on legs)

Kick plates clip onto the legs of the unit. You must order legs instead of castors to be able to have kick plates.

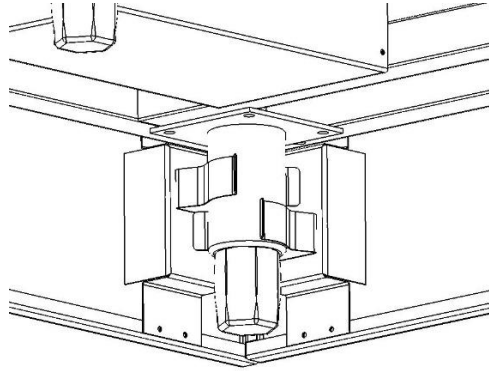
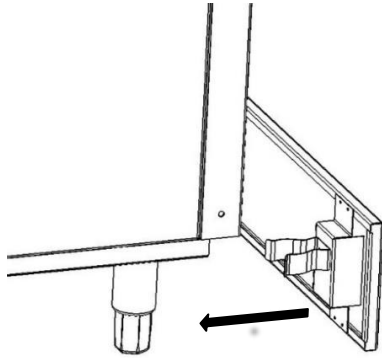

### Installation of Gantry Glass

Gantry Glass Standard

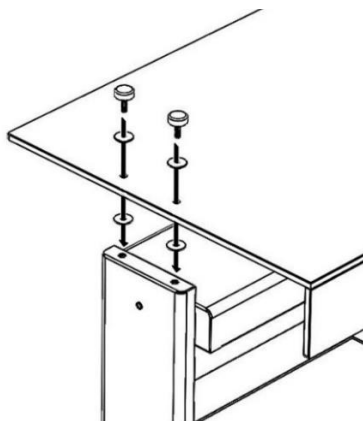

Fully Enclosed Gantry Glass

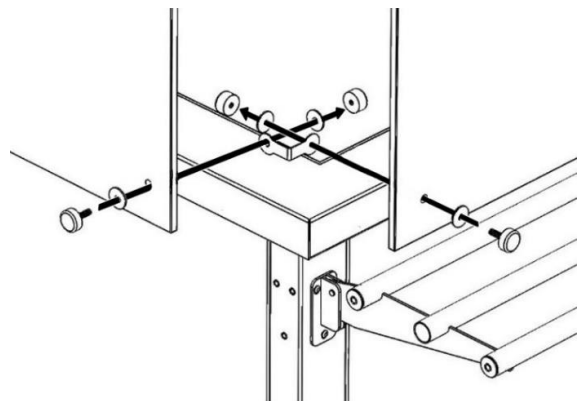

Island Gantry Glass

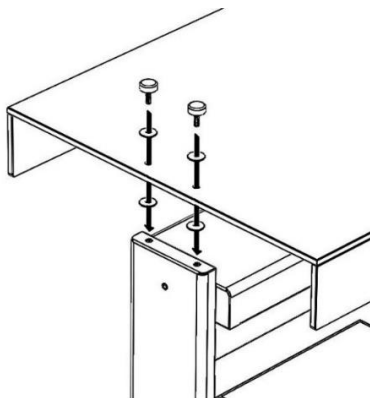

Installation or movement of shelves

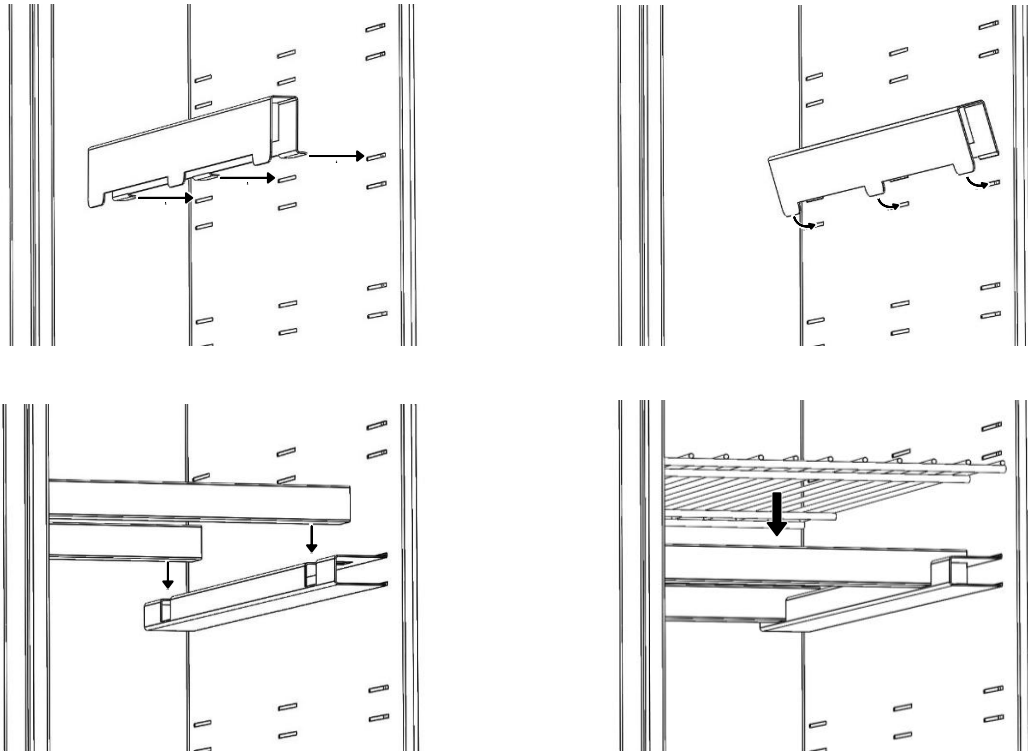



## Operating Instructions

---





The unit is designed to keep chilled product cool whilst serving. If produce is to be left for long periods of time it is advisable to return produce back to the refrigerator.

### Cupboard

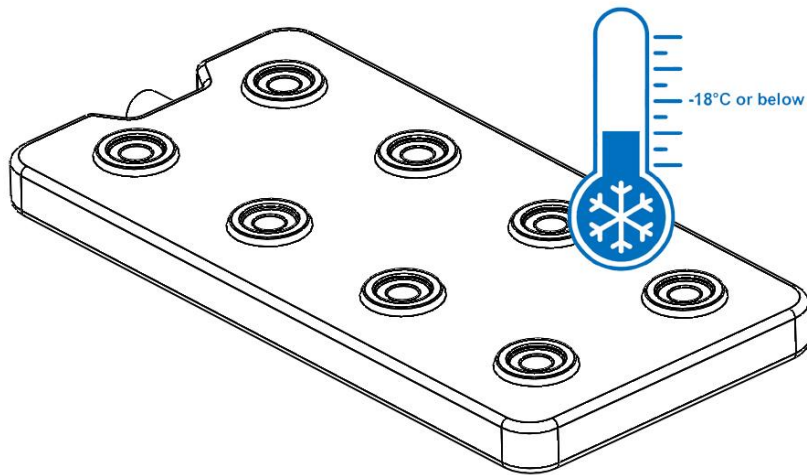
 If the unit is fitted with a gantry turn on power switch to illuminate LED lamp(s).

### Eutectic Well







-  Place Eutectic plates in a freezer overnight.
-  Only place Eutectic plates in the well on the unit prior to placing the GN containers with produce within.
-  Turn off power switch. (if fitted with gantry)
-  Remove GN containers.  
Remove Eutectic plates and rinse off any spilled food then return to the freezer for next use.



## Cleaning Instructions

---

The appliance should be cleaned after every use.

-  Turn off unit at the mains power.
-  Clean with hot soapy water.
-  With the containers removed wipe down the machine with a soft cloth, do not use abrasive materials.
-  Stainless steel cleaners maybe used and cleaning instructions on the product must be adhered to.
-  Never clean the unit with water jets.



## Maintenance Instructions

---

Ensure the appliance is isolated from the power supply before installing, cleaning or maintaining the appliance.

Maintenance and service must only be undertaken by a qualified electrician.



Parry Catering provides a complete after-sales service by offering the sales of spare parts directly to customers. Buying spares straight from the manufacturer allows customer to experience exceptional value and speedy delivery on all spare parts.

For more information on buying spares visit:

[www.parry.co.uk/parry-commercial-catering-spares](http://www.parry.co.uk/parry-commercial-catering-spares)



## Fault Finding

Fault	Check	Solution
<b>Gantry not lighting</b>	Check that the power switch is illuminated. If there is no illumination	Turn on mains power
		See an engineer to replace faulty switch
<b>Single bulbs not lighting</b>	Check if the bulb has blown	Replace with a 10W LED bulb only



## Service Information

This appliance should be routinely serviced to prolong its lifetime. Parry recommends that the appliance is serviced every 12 months by a Parry authorised engineer. Failure to service your product within the initial 12 month warranty period will cause the 24 month warranty to become void.

If the supply cord becomes damaged, it must be replaced by the manufacturer, it's service agent, or a similarly qualified person.

### Enhanced 2 Years Warranty

Parry Catering (Midlands) Ltd offer an enhanced warranty of two years (including parts and labour) on all of the Parry manufactured products. To take advantage of this you should register your warranty by logging onto the company website and filling out our simple form.

[www.parry.co.uk/the-parry-warranty](http://www.parry.co.uk/the-parry-warranty)

If you have any issues with your product and wish to request a warranty call you can contact our friendly team who will organize a Parry approved service engineer to attend and fix your problem.

All warranty requests can be sent to [warranty@parry.co.uk](mailto:warranty@parry.co.uk) alternatively call our warranty department for technical assistance on **01332 875544**





## Wiring Diagram

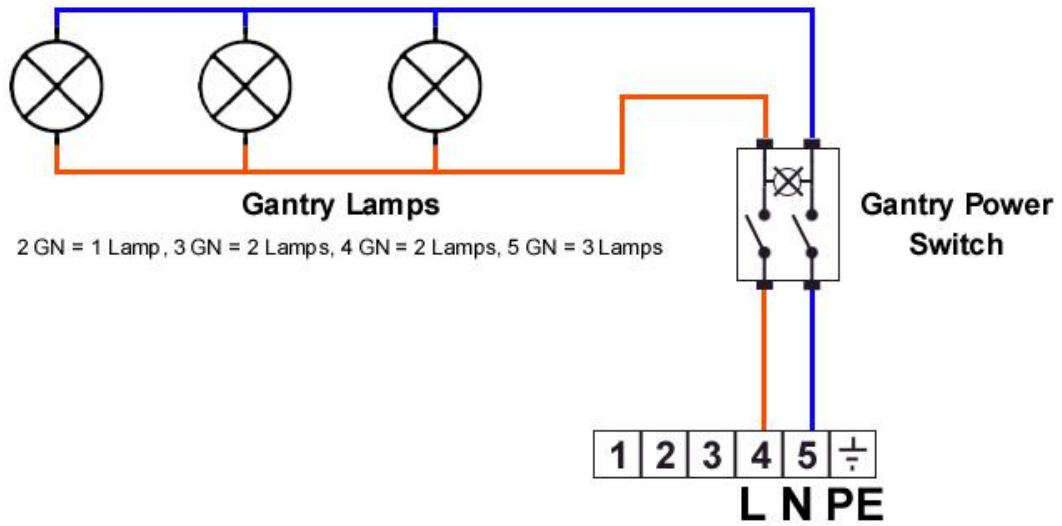



# Exploded View

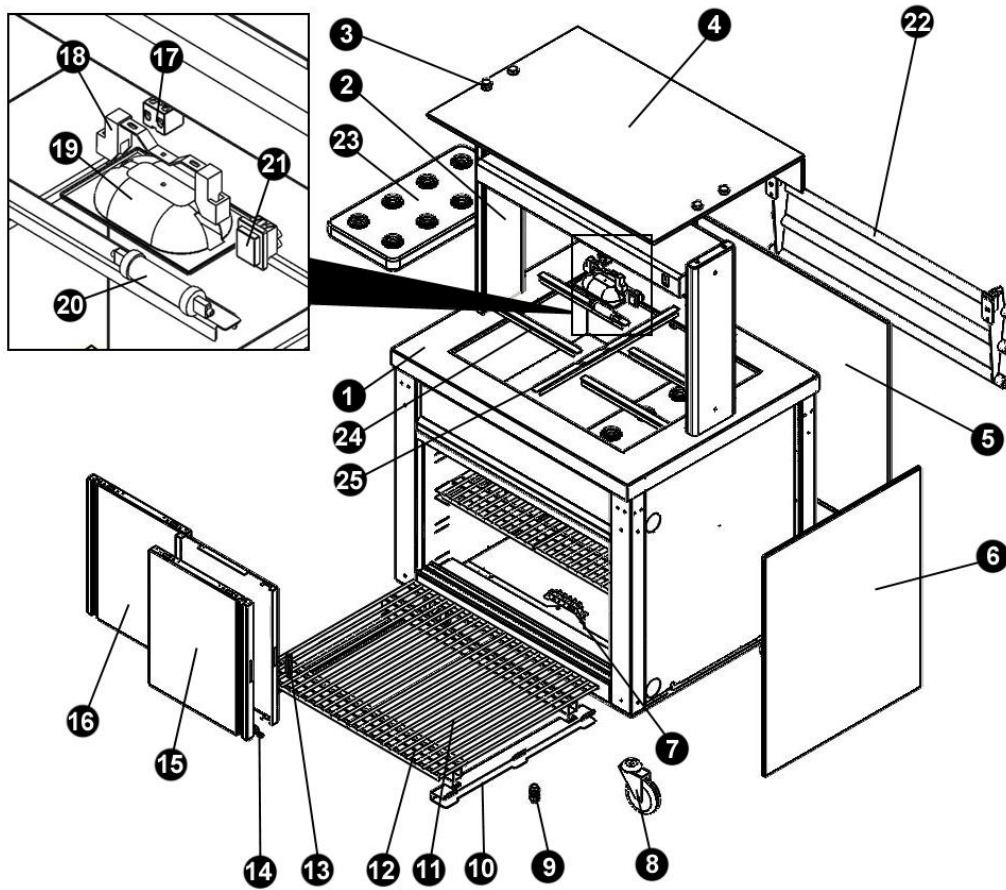



## Parts List

Part Number	Description	Code
1	Main Body	No Code
2	Gantry Assembly <i>(Please note gantries are factory fitted)</i>	FS-AW2G FS-AW3G FS-AW4G FS-AW5G
3	Glass Fixing	FS-GLASSFIXBOLT
4	Gantry Glass <i>(Standard Glass fitted with Gantry)</i>	FS-AW2G = FS-PLGL2TOP FS-AW3G = FS-PLGL3TOP FS-AW4G = FS-PLGL4TOP FS-AW5G = FS-PLGL5TOP <b>Other Options available, Island Glass &amp; Assisted Serve. Please see extras</b>
4a	Glass Rubber Gasket	FS-RUBBWASH
5	Rear Cladding	
6	Side Cladding	
7	Terminal Block	TB6POLET
8	Braked Castor	CASTOR100BHD <b>After Oct 2021 castor in use</b> CASTOR100HDB/C
9	Gland	GLAND0M16
9a	Gland Nut	LOCKNTM16
10	Shelf Support Rail	No Code
11	Rack	HCWIRESELF
12	Shelf Supporting Bar (Sizes Vary)	No Code
13	Door Magnet	DRCT00010
14	Door Roller	DOOROLLER
15	RH Door Assembly	No Code
16	LH Door Assembly	No Code
17	Ceramic Terminal Block	BTCER2WAY
18	Lamp Holder	CLICHold
19	Lamp Reflector	CLICREFLECTOR
20	10w LED Lamp	CLIC300LED
21	Power Switch	SWRE00011

22	Tray Slide Assembly (Front) <i>Optional Extra</i>	<b>Tubed Tray Rail</b> FS-T2 (Size 2 GN) FS-T3 (Size 3 GN) FS-T4 Size 4 GN) FS-T5 (Size 5 GN) <b>Plain Tray Slide</b> FS-ST2 (Size 2 GN) FS-ST3 (Size 3 GN) FS-ST4 Size 4 GN) FS-ST5 (Size 5 GN)
23	Eutectic Plate	EP1/1GN
24	Side BM Divide	
25	Centre BM Divide	
	Side Tray Slide	<b>Tubed Tray Rail</b> FS-TSIDE <b>Plain Tray Slide</b> FS-STSIDE
	Mains Cable	MLEAD25

### Extras

Description	Code
Island Glass	FS-IG2 (Size 2 GN) FS-IG3 (Size 3 GN) FS-IG4 Size 4 GN) FS-IG5 (Size 5 GN)
Assisted Glass	FS-AG2 (Size 2 GN) FS-AG3 (Size 3 GN) FS-AG4 (Size 4 GN) FS-AG5 (Size 5 GN)



## Warranty Information

---

The manufacturer's warranty is only valid in the UK mainland. Northern Ireland, Western Isles, Inner Hebrides and Islands are parts only warranty. Please be aware that the warranty starts from the date of purchase from Parry and not the sale or installation date of the equipment.

To be eligible for a 2 year warranty, products must be serviced at least once within the first 12 months of purchase.

All service calls will be carried out between 8am and 5pm, Monday to Friday.

Your warranty is invalid if your equipment has not been installed in accordance with the manufacturer's instructions. The misuse, alteration or unauthorised repairs of the equipment will also invalidate the warranty.

During the warranty period it is at Parry's discretion whether to repair or replace the equipment.

The warranty only applies if the equipment has been used in a professional manner following the manufacturer's instructions and maintenance guidelines.

The warranty covers defects in the material and component failure only. We are not liable for trading loss, loss of perishable items, water damage or loss due to injury or fire damage.

Please ensure you have referred to the manufacturer's instruction before placing a warranty call.

Contact our warranty department on **01332 875544** for technical assistance.











Please have your model number ready before calling.

All warranty requests must be submitted to [warranty@parry.co.uk](mailto:warranty@parry.co.uk).

Failure to pay any warranty charges will result in your warranty being put on hold until the bill has been settled. Any issues regarding the raised charges should be put in writing to our warranty department for further investigation.

Register your product by visiting our website [www.parry.co.uk](http://www.parry.co.uk)

### **Not covered under warranty**

-  Fault due to incorrect installation, poor maintenance or equipment abuse.
-  Resetting of equipment or circuit breakers.
-  Faulty electrics – e.g. customer's plug socket, plug, wiring, junction box fault, wrong fuse.
-  Products must be serviced within the first 12 months to be eligible for the 2 year warranty
-  Product not covered by warranty if combustible materials have been used, e.g. plastic trays.
-  Foil used on racks, blockages and lime scale issues.
-  Failure to grant access for pre-arranged service call.
-  Equipment that has been set up or used incorrectly e.g. dishwasher detergents, levelling and setting up of doors on a six burner cooker.
-  Excessive carbon build-up on griddle plates or overuse of lava rock on chargrills. (Recommended use by Parry no more than 2kg.)
-  All of the above points are not covered by warranty and any costs incurred, because of the above, will be forwarded to the parties responsible for placing the call.



## Disposal & Recycling

---

This appliance is marked according to the European Directive 2002/96/EC on Waste Electrical and Electronic Equipment (WEEE).

By ensuring this product is disposed of correctly, you will help prevent potential negative consequences for the environment and human health which could otherwise be caused by inappropriate waste handling of this product.

A symbol on the product, or on the documents accompanying the product, indicates that

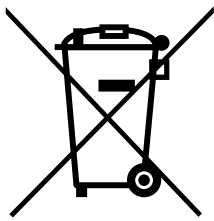

this appliance may not be treated as household waste. Instead it should be handed over to the applicable collection point for the recycling of electrical and electronic equipment.

Disposal must be carried out in accordance with local environmental regulations for waste disposal.





For more detailed information about treatment, recovery and recycling of this product, please contact your local city office, your household waste disposal service or the shop where you purchased the product.

Parry Catering recognises our obligations to the EU DIRECTIVE covering the waste disposal of electrical and electronic equipment (WEEE). Parry Catering are committed to this policy in order to help conserve the environment.

At the end of this unit's life you **MUST** dispose of it in an approved manner. You **MUST** not discard the unit or place it in the refuse bin.

You have several options:

-  Take the unit to an approved WEEE scheme company, there will be one in your area.
-  Take the unit to an approved waste disposal site; many sites are managed by your local authority.
-  Contact the units manufacturer, importer or their agent; the contact details will be on the unit.

There will probably be a charge for this service which will depend on the physical size and location of the unit. You will be given a collection price for a curb side collection based on commercial rates prevailing at the time.

It should be noted that the unit to be collected should be suitably packed and sealed to prevent dangerous gases and fluids from escaping. The condition of the unit must also be clean to comply with health and safety regulations.