

FS-HB2/3/4/5

HOT CUPBOARD WITH DRY WELL BAIN MARIE AND QUARTZ HEATED GANTRY

Flexi-Serve mobile plain top hot cupboard with dry bain marie top. Available in 4 size options to accommodate between 2 and 5 1/1 GN pans at 150mm deep.

Designed to run on one plug to minimise power consumption, whilst keeping food at the optimal serving temperature.

Use as a single servery or combine with other Flexi-Serve modules to create your perfect counter layout.



FLEXI SERVE

MADE IN BRITAIN

Model Specification	FS-HB2	FS-HB3	FS-HB4	FS-HB5
Dimensions (w x d x h) mm	860x700x900	1160x700x900	1495x700x900	1830x700x900
Temperature Range (°C)	30-90	30-90	30-90	30-90
Total Power kW (Unit only)	2.0	2.5	2.5	2..25
Total Power kW (Unit and Gantry)	2.2	2.9	2.9	2.85
Number of gantry bulbs	1	2	2	3
Plug Type	13 Amp	13 Amp	13 Amp	13 Amp
Weight Packed (kg)	96	136	150.5	191.5
Weight Unpacked (kg)	86	108	128.5	169.5
Dimensions incl. Gantry & Trayslide	860x983x1440	1160x983x1440	1495x983x1440	1830x983x1440

FEATURES

- GN compatible dry-well Bain Marie accommodates 150mm deep pans, bridging bars supplied
- Fan assisted hot cupboard with wire shelves holds food at ideal temperature for service
- Removable hot cupboard shelves and supports makes cleaning easier, shelves fit in a dishwasher
- Various colours of fascia panels available
- Adjustable hot cupboard shelf positions offer increased flexibility and capacity when required
- Narrow 700mm width fits easily through doorways
- 4 heavy duty 100mm locking castors
- 10mm deep bonded glass to gantry

HOT CUPBOARD WITH DRY WELL BAIN MARIE AND QUARTZ HEATED GANTRY

FS-HB2 LINE DRAWING

Dimensions in mm

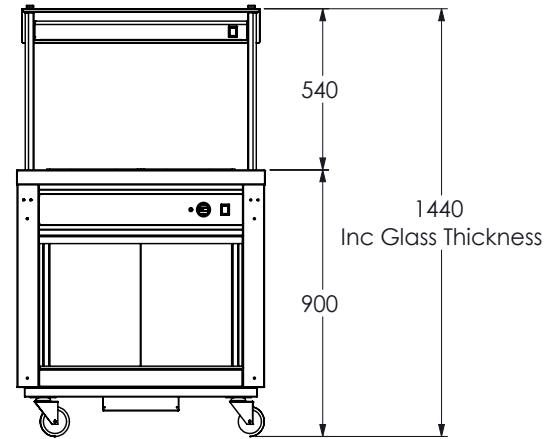
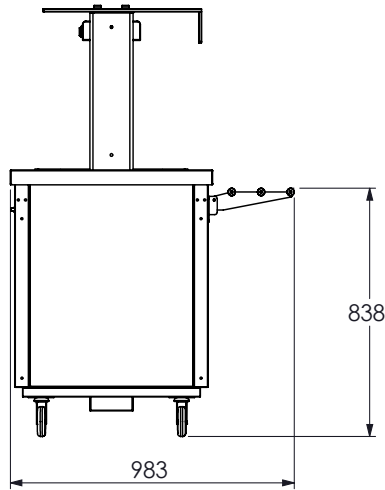
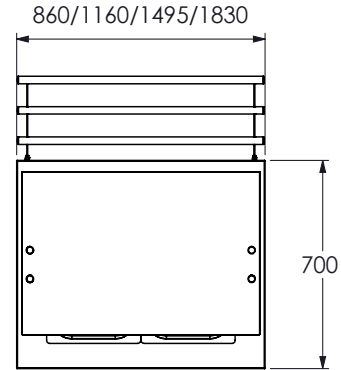
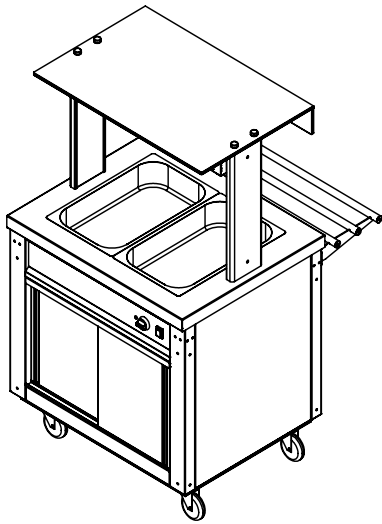

757 With tray slide in the down position

AVAILABLE ACCESSORIES

- Island glass or Assisted glass at an additional cost