

FLEXI+SERVE



FS-HT Range

Available as:
FS-HT2, FS-HT3, FS-HT4, FS-HT5
Including Gantry versions & 800mm Height



British Built for Purpose.





Welcome to Parry

Parry is one of the UK's foremost manufacturers of high-quality Stainless Steel Fabricated Products with a 40-year heritage rooted in British craftsmanship.

At Parry, quality and service are second nature. Striving to exceed our customers' expectations is not just our motto; it's the very heartbeat of our business. Our commitment to our customers is reflected in the **Parry 4E Standard Inspection Body stating that all our products are:**



Easy to use



Easy to maintain



Easy to clean



Easy to repair

Our ranges of Stainless Steel Products have been specifically designed with the consumer in mind and are tailored and compliant to your specific industry sector. All our products are 4E Compliant and meet EU & UK regulations, where applicable. The Parry brand stands for quality, reliability and value.

Our British designed products have been created by our expert in-house development team and manufactured to exacting standards using Industry specified grade of European stainless steel and holding relevant EU & UK certification for all product.

ISO9001 certification and continual investment in the training and development of our highly skilled, artisan workforce means that our clients have genuine peace of mind that they are buying hand crafted, quality products supported by five-star customer service. All Parry products meet EU regulations for their respective sector.

We are LEAN manufacturers, minimising waste, maximising productivity. We are proud to run an operation that is committed to minimising our impact on the environment.

Our equipment and furniture are manufactured in our 45,000 sq ft manufacturing facility in Draycott, Derbyshire in England's industrial heartland. Products are made to order if not available in our stocked items which means you can choose from 600 products, offering over 3,500 variants, with short lead times to suit your specific needs. That means you get exactly what you need when you need it.

Our product information can be found here, in our brochure or on our website www.parry.co.uk.

You have my personal commitment that Parry will exceed your expectations. Should you have any questions please contact your distributor. Alternatively, our customer services team will be happy to help you on **01332 875544**.

Mark Banton MBA
Managing Director



Contents.....	1
Product Overview	2-4
Safety Instructions	5
Installation Instructions	5-9
Operating Instructions	10
Cleaning Instructions	11
Maintenance Instructions.....	12
Fault Finding	13
Service Information.....	14
Wiring Diagram	15
Exploded View	16
Parts List	17-18
Warranty Information.....	19
Disposal & Recycling	20

Parry Catering Equipment (Midlands) Ltd, Town End Road, Draycott, Derby, DE72 3PT.
Sales Tel: 01332 875544





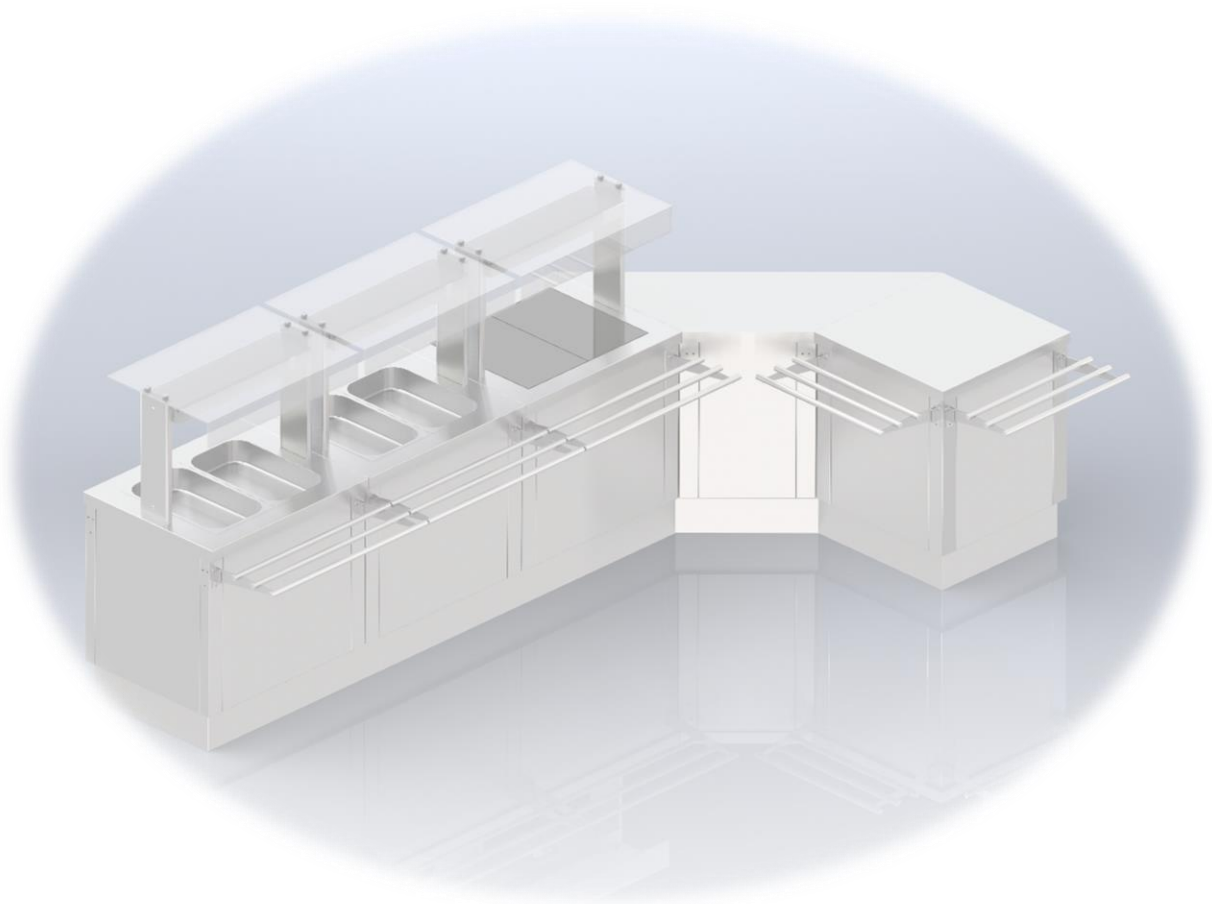

Product Overview

The new Parry Flexi-Serve range has been designed specifically to suit the requirements of the user. The FS-HT Range comprises of a fan assisted heated cupboard and heated Ceran tiles to the top of the unit.

The Flexi-Serve range can be manufactured with or without a gantry.



It leads the industry in:

-  Design and aesthetic appeal
-  Performance
-  Power
-  Functionality
-  After sales support

 **900mm Height Range (Standard)**

Features	FS-HT2	FS-HT3	FS-HT4	FS-HT5
External Dimensions (mm)	860(w)	1160(w)	1495(w)	1830(w)
	700(d) x 900 (h)			
Internal Cupboard (mm)	705(w)	1005(w)	1340(w)	1675(w)
	580 (d) x 410 (h)			
Shelves	2 Layers supplied 4 Positions			
Height with Gantry (mm) Optional	1440 (h)			
Total Power (Watts)	1860	2040	2220	2400
Total Power with Gantry (Watts)	2060	2440	2620	3000
Voltage	230V 50Hz ~			
Weight (kg)	86	108	128.5	169.5
Weight with Gantry (kg)	108	137	176	226.5

800mm Height Range







Features	FS-HT2-8	FS-HT3-8	FS-HT4-8	FS-HT5-8
External Dimensions (mm)	860(w)	1160(w)	1495(w)	1830(w)
	700(d) x 800 (h)			
Internal Cupboard (mm)	705(w)	1005(w)	1340(w)	1675(w)
	580 (d) x 310 (h)			
Shelves	2 Layers supplied 3 Positions			
Height with Gantry (mm) <i>Optional</i>	1340 (h)			
Total Power (Watts)	1860	2040	2220	2400
Total Power with Gantry (Watts)	2060	2440	2620	3000
Voltage	230V 50Hz ~			
Weight (kg)	76.5	93	113	149.5
Weight with Gantry (kg)	96.5	122	157	202



Safety Instructions

The unit has been designed to easily be moved into position and has four braked castors to lock in position to avoid movement whilst in operation. Alternatively, the units can be supplied on adjustable legs for fixed position.

This appliance has been designed to warm products and therefore during its use parts of the appliance will become very hot. All personnel must be given adequate supervision and training in the safe use of this appliance.



-  All appliances other than those fitted with a sealed moulded plug must be fitted with a sealed moulded plug and must be fitted by a qualified electrician, in accordance with current regulations.
-  The unit should be installed in compliance with the Installation Instructions and the National regulations in force at the time. Particular attention should be paid to the Health and Safety at Work Act.
-  To prevent shocks, all appliances whether gas or electric, must be earthed.
-  To avoid scratching the highly polished exterior surface of this equipment whilst in transit, the protective film on the exterior surfaces has NOT been removed.
-  It is IMPORTANT that this protective film is peeled off before the equipment is used.
-  Ensure that vents intended to provide air flow in and around the unit are not obstructed.
-  Ensure the appliance is isolated from the power supply before installing, cleaning or maintaining the appliance





Installation Instructions

The unit has been designed to easily be moved into position and has four braked castors to lock in position to avoid movement whilst in operation. Alternatively, the units can be supplied on adjustable legs for fixed position.

Mobile Use

-  Position the Flexi-Serve unit in the serving position and secure in place using the 4 braked castors.
-  Units fitted with 13amp plug, plug into a suitable socket.

Static Use

-  Position the Flexi-Serve unit in the serving position and adjust legs to suit the surface.
-  Units fitted with 13amp plug, plug into a suitable socket.

Taking Out the Doors

Slide door to the middle

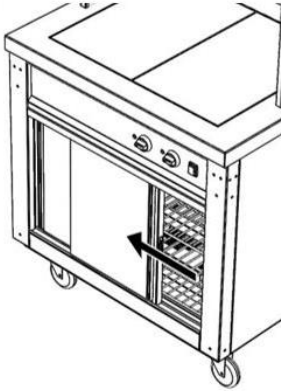

Lift door up

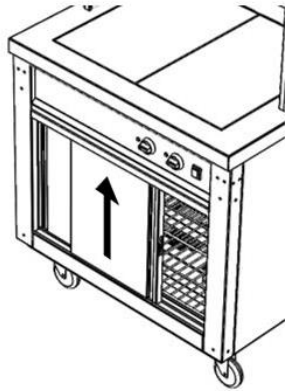

Angle bottom of door forward



Pull door down

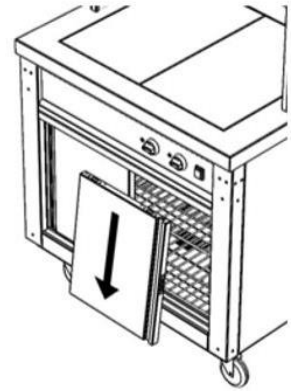

Attaching the Tray Slide onto the Unit

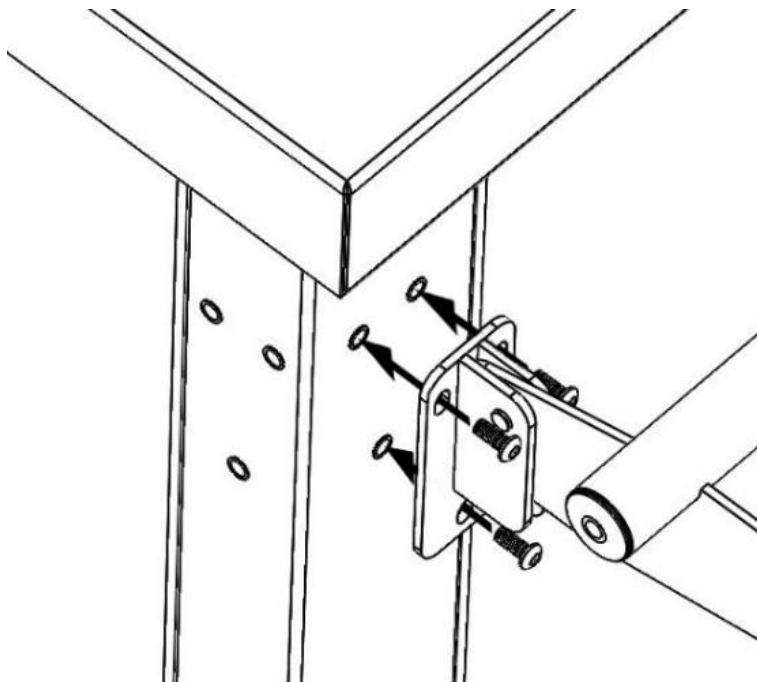

Removing the Side and Front Panels

Unscrew the screw from the bottom of the unit with the supplied Allen Key.

Using the finger cutouts on the bottom of the unit pull the panel out and then slide down.

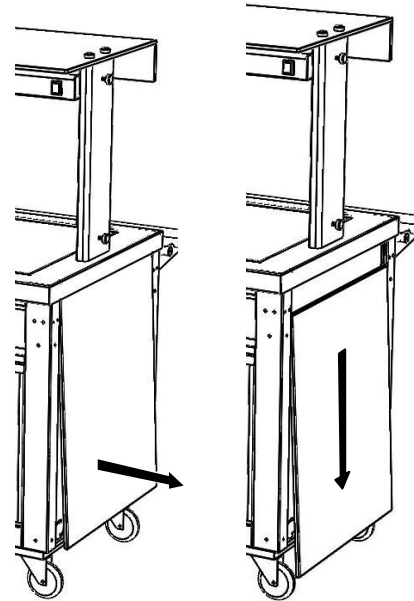
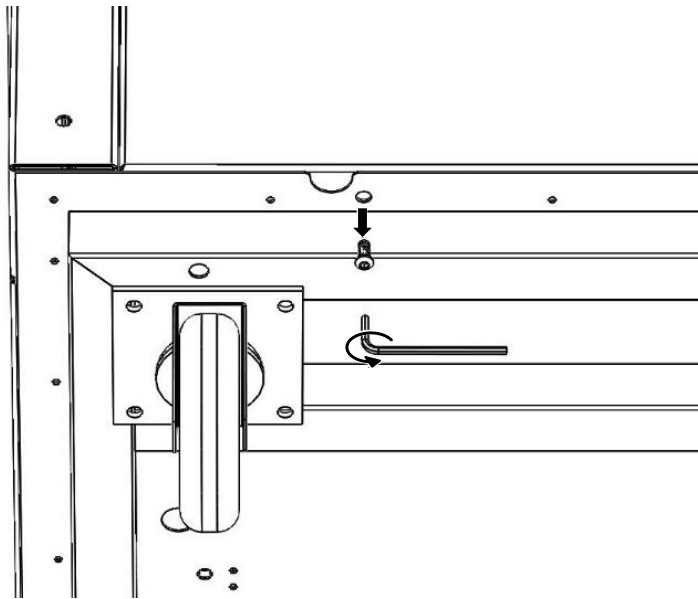

Fixing the Connecting Plates and Trims to the Units

Push the two units together that you require the joining plate to be attached to. Screw in the supplied Allen screws with the supplied Allen key.

Top of Unit

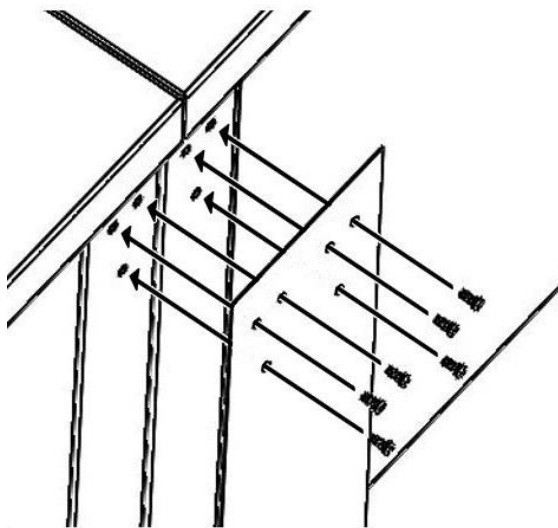

Bottom of Unit

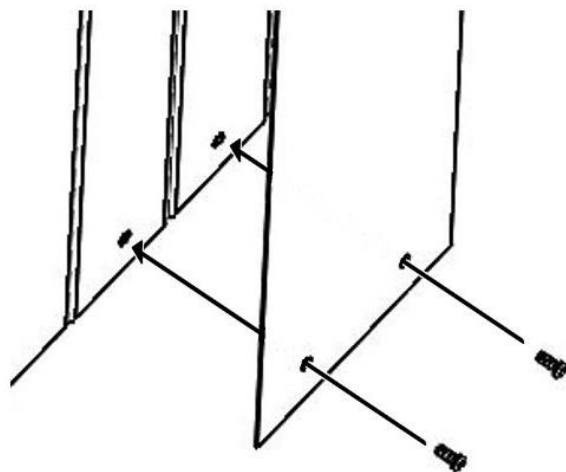

Kick Plate Installation (If fitted on legs)

Kick plates clip onto the legs of the unit. You must order legs instead of castors to be able to have kick plates.

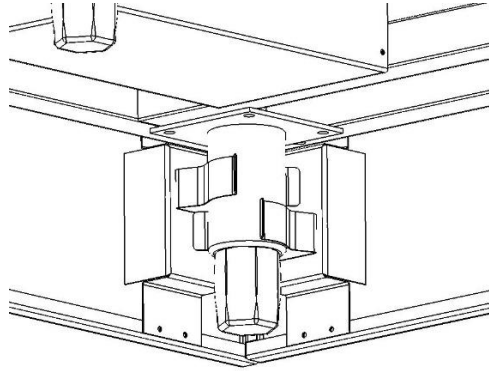
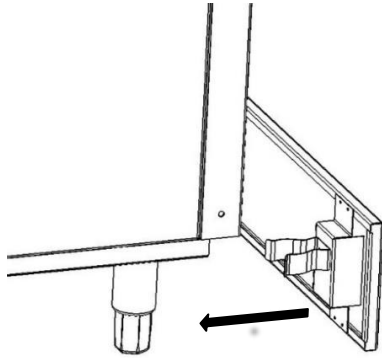

Installation of Gantry Glass

Gantry Glass Standard

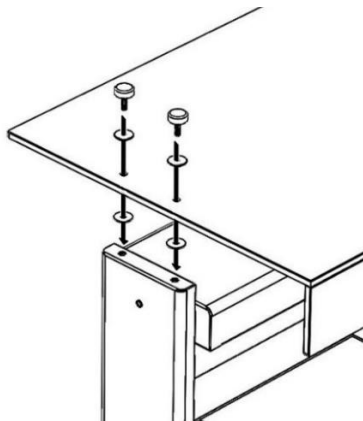

Fully Enclosed Gantry Glass

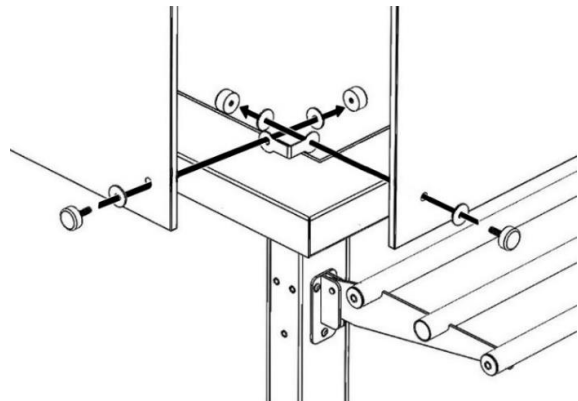

Island Gantry Glass

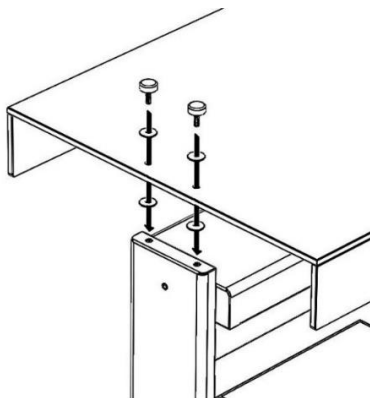

Installation or movement of shelves

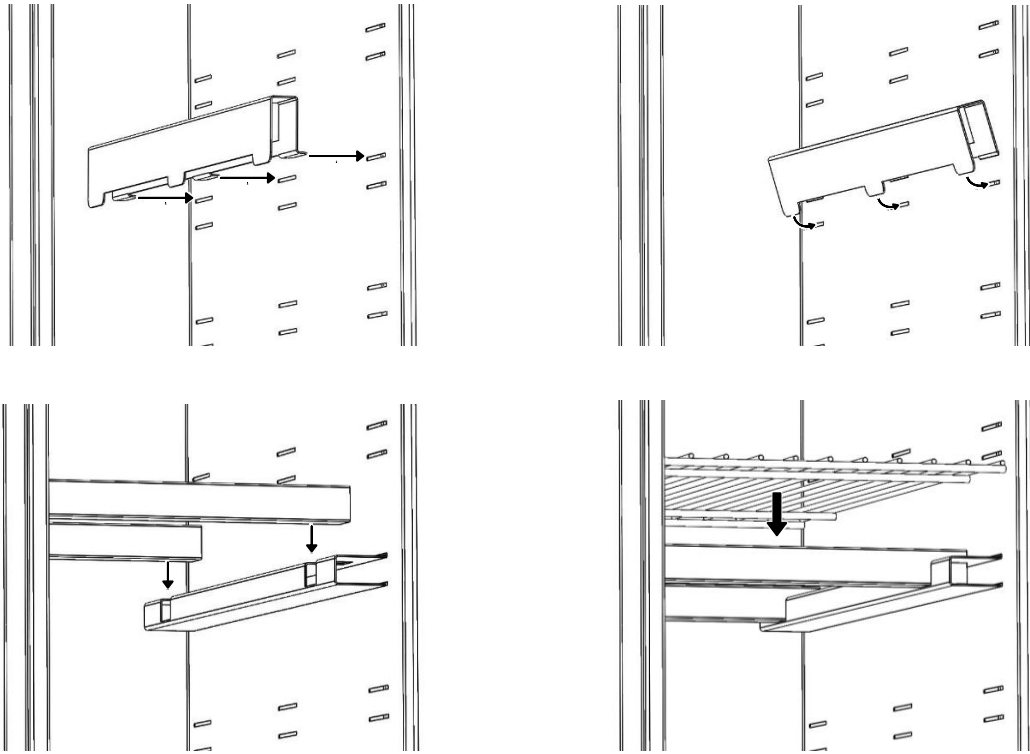







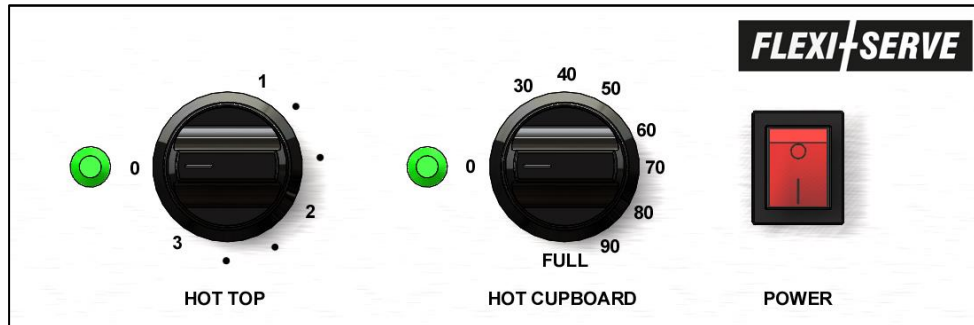



Operating Instructions







The unit is designed to keep food warm whilst serving and should never be used to try to cook food.



Hot Cupboard

-  Turn on the mains power switch.
-  The Hot Cupboard fan will run.
-  Turn on Hot Cupboard control to full for 15 minutes to allow to warm up.
-  Whilst the hot cupboard is heating the green indicator lamp will be displayed.
-  When the hot cupboard achieves temperature, the lamp will distinguish.
-  This will turn on and off to maintain temperature throughout use.
-  Once the Hot Cupboard is up to temperature, place cooked hot food in suitable metal containers into the hot cupboard.
-  Adjust the dial to desired level The Hot Cupboard will operate between 30-90°C.

Hot Top

-  Turn on Hot Top by selecting setting number 3 and allow to fully warm up for 15 minutes.
-  Whilst the dial is set on number 3 the green indicator lamp will be displayed.
-  If fitted with the optional gantry, turn on the power switch to this.
-  Once the Hot Top is up to temperature place suitable serving containers on top. Ensure that the containers have a flat base to ensure optimum contact to the Hot Top.
-  Adjust the dial to desired level. Setting 3 is power is on permanently. Positions from 1 – 2 will regulate the power on and off. Setting these depends on the food mass that is stored in the containers. Test to ensure food is kept at serving temperature.
-  Whilst serving is not in place best practice is to keep the lids on the containers.







After Use

-  Turn off power dials to the Hot Cupboard, Hot Top and power switch



Cleaning Instructions

The appliance should be cleaned after every use.

-  Allow unit to cool down before cleaning
-  Turn off unit at the mains power.
-  Clean Ceran top with hot soapy water.
-  With the containers removed wipe down the machine with a soft cloth, do not use abrasive materials.
-  Stainless steel cleaners maybe used and cleaning instructions on the product must be adhered to.
-  Never clean the unit with water jets.



Maintenance Instructions

Ensure the appliance is isolated from the power supply before installing, cleaning or maintaining the appliance.

Maintenance and service must only be undertaken by a qualified electrician.



Parry Catering provides a complete after-sales service by offering the sales of spare parts directly to customers. Buying spares straight from the manufacturer allows customer to experience exceptional value and speedy delivery on all spare parts.

For more information on buying spares visit:

www.parry.co.uk/parry-commercial-catering-spares



Fault Finding

Fault	Check	Solution
Hot plates not heating	Check that the power switch is illuminated. If there is no illumination	Turn on mains power
Hot Cupboard not heating	Check that the power switch is on and the thermostat is selected to desired temperature.	Turn on mains power
		See an engineer to replace faulty switch, element or thermostat.
Gantry not lighting	Check that the power switch is illuminated. If there is no illumination	Turn on mains power
		See an engineer to replace faulty switch
Single bulbs not lighting	Check if the bulb has blown	Replace with a 200W bulb



Service Information

This appliance should be routinely serviced to prolong its lifetime. Parry recommends that the appliance is serviced every 12 months by a Parry authorised engineer. Failure to service your product within the initial 12 month warranty period will cause the 24 month warranty to become void.

If the supply cord becomes damaged, it must be replaced by the manufacturer, it's service agent, or a similarly qualified person.

Enhanced 2 Years Warranty

Parry Catering (Midlands) Ltd offer an enhanced warranty of two years (including parts and labour) on all of the Parry manufactured products. To take advantage of this you should register your warranty by logging onto the company website and filling out our simple form.

www.parry.co.uk/the-parry-warranty

If you have any issues with your product and wish to request a warranty call you can contact our friendly team who will organize a Parry approved service engineer to attend and fix your problem.

All warranty requests can be sent to warranty@parry.co.uk alternatively call our warranty department for technical assistance on **01332 875544**





Wiring Diagram

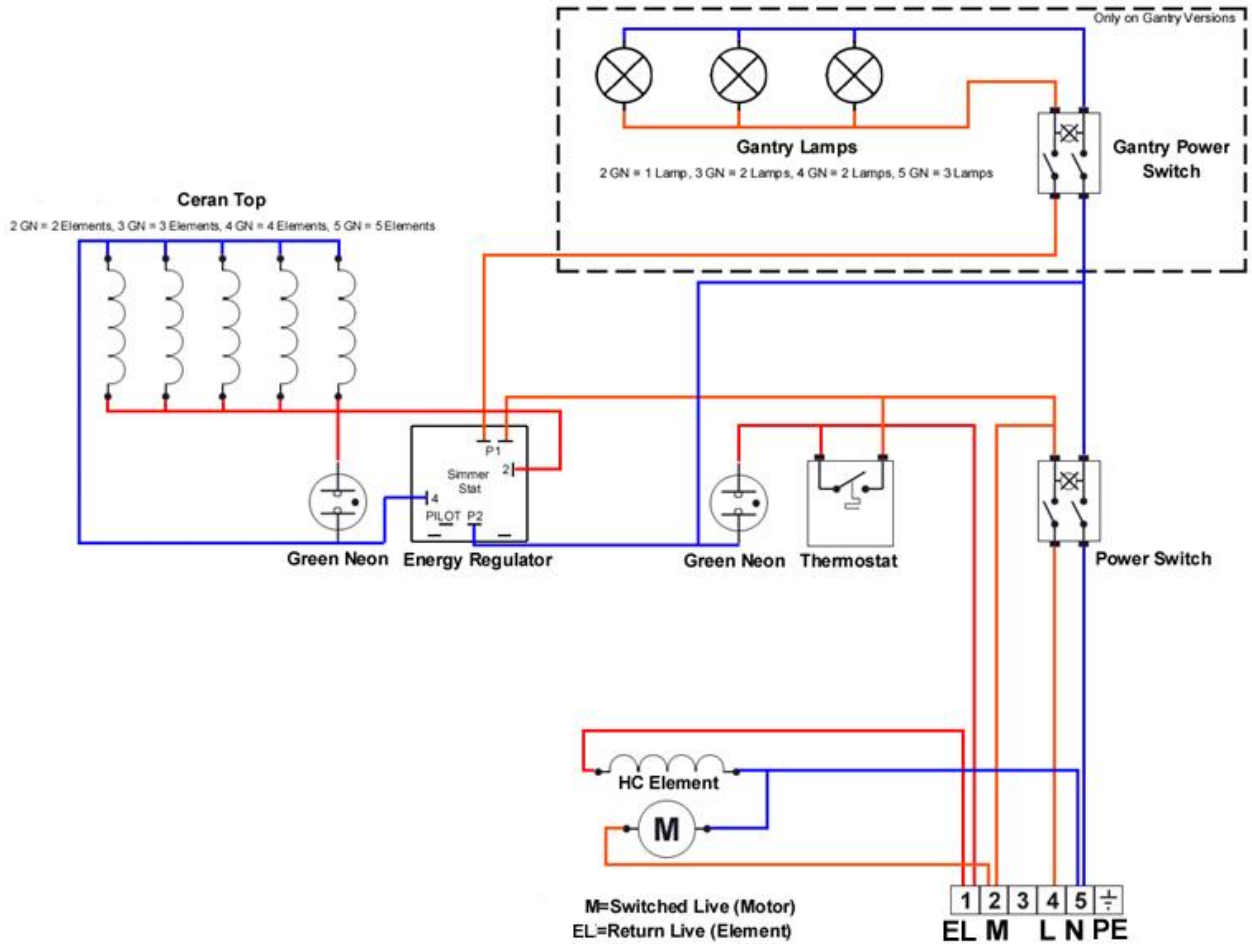



Exploded View

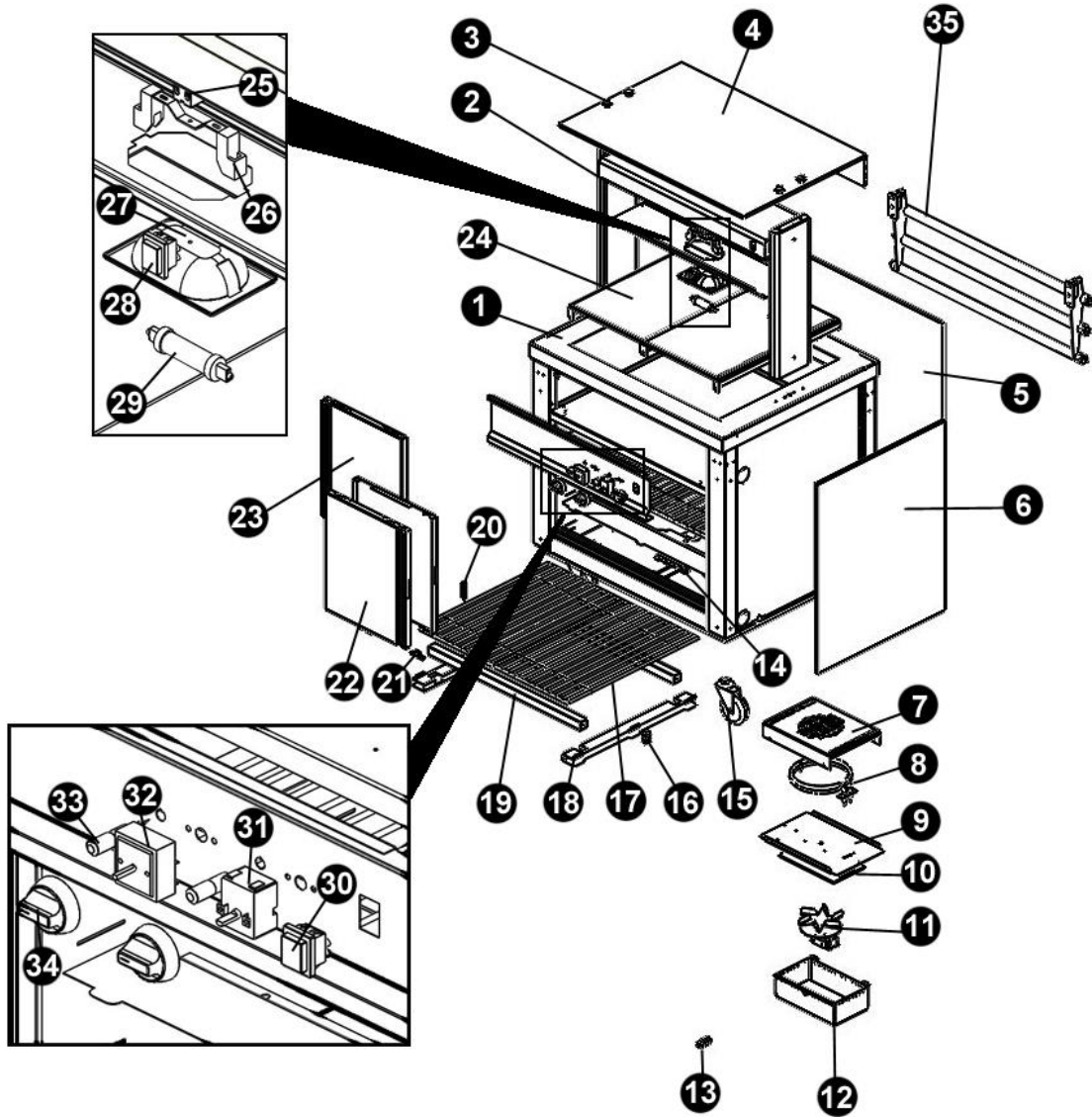



Parts List

Part Number	Description	Code
1	Main Body	No Code
2	Gantry Assembly <i>(Please note gantries are factory fitted)</i>	FS-HCHT2G FS-HCHT3G FS-HCHT4G FS-HCHT5G
3	Glass Fixing	FS-GLASSFIXBOLT
4	Gantry Glass <i>(Standard Glass fitted with Gantry)</i>	FS-HCHT2G = FS-PLGL2TOP FS-HCHT3G = FS-PLGL3TOP FS-HCHT4G = FS-PLGL4TOP FS-HCHT5G = FS-PLGL5TOP Other Options available, Island Glass & Assisted Serve. Please see extras
4a	Glass Rubber Gasket	FS-RUBBWASH
5	Rear Cladding	
6	Side Cladding	
7	Heater Vent Cover	No Code
8	Element	FS-RING15ELEM
9	Motor Plate	No Code
10	Insulation Board	FS-HBINSUL
11	Motor	P9EOMOTOR
12	Motor Cover	No Code
13	Gland	GLAND0M16
13a	Gland Nut	LOCKNTM16
14	Terminal Block	TB6POLET
15	Braked Castor	CASTOR100BHD After Oct 2021 castor in use CASTOR100HDB/C
16	Gland	GLAND0M16
16a	Gland Nut	LOCKNTM16
17	Rack	HCWIRESHELF
18	Shelf Support Rail	No Code
19	Shelf Supporting Bar (Sizes Vary)	No Code
20	Door Magnet	DRCT00010
21	Door Roller	DOOROLLER

22	RH Door Assembly	No Code
23	LH Door Assembly	No Code
24	Ceran Top	CERAN530325
25	Ceramic Terminal Block	BTCER2WAY
26	Lamp Holder	CLICHOLD
27	Lamp Reflector	CLICREFLECTOR
28	Power Switch	SWRE00011
29	200w Quartz Lamp	CLIC200LAMP
30	Power Switch	SWRE00011
31	Thermostat	TMST5513015
32	Energy Regulator	SATT37071
33	Green Neon	LNGN2211P
34	Control Knob	KNOBPHEN
35	Tray Slide Assembly (Front) <i>Optional Extra</i>	Tube Tray Rail FS-T2 (Size 2 GN) FS-T3 (Size 3 GN) FS-T4 Size 4 GN) FS-T5 (Size 5 GN) Plain Tray Slide FS-ST2 (Size 2 GN) FS-ST3 (Size 3 GN) FS-ST4 Size 4 GN) FS-ST5 (Size 5 GN)
	Side Tray Slide	Tube Tray Rail FS-TSIDE Plain Tray Slide FS-STSIDE
	Mains Cable	MLEAD25

Extras

Description	Code
Island Glass	FS-IG2 (Size 2 GN) FS-IG3 (Size 3 GN) FS-IG4 Size 4 GN) FS-IG5 (Size 5 GN)
Assisted Glass	FS-AG2 (Size 2 GN) FS-AG3 (Size 3 GN) FS-AG4 (Size 4 GN) FS-AG5 (Size 5 GN)



Warranty Information

The manufacturer's warranty is only valid in the UK mainland. Northern Ireland, Western Isles, Inner Hebrides and Islands are parts only warranty. Please be aware that the warranty starts from the date of purchase from Parry and not the sale or installation date of the equipment.

To be eligible for a 2 year warranty, products must be serviced at least once within the first 12 months of purchase.

All service calls will be carried out between 8am and 5pm, Monday to Friday.

Your warranty is invalid if your equipment has not been installed in accordance with the manufacturer's instructions. The misuse, alteration or unauthorised repairs of the equipment will also invalidate the warranty.

During the warranty period it is at Parry's discretion whether to repair or replace the equipment.

The warranty only applies if the equipment has been used in a professional manner following the manufacturer's instructions and maintenance guidelines.

The warranty covers defects in the material and component failure only. We are not liable for trading loss, loss of perishable items, water damage or loss due to injury or fire damage.

Please ensure you have referred to the manufacturer's instruction before placing a warranty call.

Contact our warranty department on **01332 875544** for technical assistance.











Please have your model number ready before calling.

All warranty requests must be submitted to warranty@parry.co.uk.

Failure to pay any warranty charges will result in your warranty being put on hold until the bill has been settled. Any issues regarding the raised charges should be put in writing to our warranty department for further investigation.

Register your product by visiting our website www.parry.co.uk

Not covered under warranty

-  Fault due to incorrect installation, poor maintenance or equipment abuse.
-  Resetting of equipment or circuit breakers.
-  Faulty electrics – e.g. customer's plug socket, plug, wiring, junction box fault, wrong fuse.
-  Products must be serviced within the first 12 months to be eligible for the 2 year warranty
-  Product not covered by warranty if combustible materials have been used, e.g. plastic trays.
-  Foil used on racks, blockages and lime scale issues.
-  Failure to grant access for pre-arranged service call.
-  Equipment that has been set up or used incorrectly e.g. dishwasher detergents, levelling and setting up of doors on a six burner cooker.
-  Excessive carbon build-up on griddle plates or overuse of lava rock on chargrills. (Recommended use by Parry no more than 2kg.)
-  All of the above points are not covered by warranty and any costs incurred, because of the above, will be forwarded to the parties responsible for placing the call.



Disposal & Recycling

This appliance is marked according to the European Directive 2002/96/EC on Waste Electrical and Electronic Equipment (WEEE).

By ensuring this product is disposed of correctly, you will help prevent potential negative consequences for the environment and human health which could otherwise be caused by inappropriate waste handling of this product.

A symbol on the product, or on the documents accompanying the product, indicates that

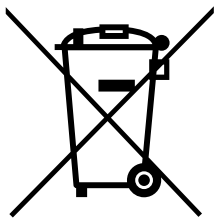

this appliance may not be treated as household waste. Instead it should be handed over to the applicable collection point for the recycling of electrical and electronic equipment.

Disposal must be carried out in accordance with local environmental regulations for waste disposal.





For more detailed information about treatment, recovery and recycling of this product, please contact your local city office, your household waste disposal service or the shop where you purchased the product.

Parry Catering recognises our obligations to the EU DIRECTIVE covering the waste disposal of electrical and electronic equipment (WEEE). Parry Catering are committed to this policy in order to help conserve the environment.

At the end of this unit's life you **MUST** dispose of it in an approved manner. You **MUST** not discard the unit or place it in the refuse bin.

You have several options:

-  Take the unit to an approved WEEE scheme company, there will be one in your area.
-  Take the unit to an approved waste disposal site; many sites are managed by your local authority.
-  Contact the units manufacturer, importer or their agent; the contact details will be on the unit.

There will probably be a charge for this service which will depend on the physical size and location of the unit. You will be given a collection price for a curb side collection based on commercial rates prevailing at the time.

It should be noted that the unit to be collected should be suitably packed and sealed to prevent dangerous gases and fluids from escaping. The condition of the unit must also be clean to comply with health and safety regulations.