

# robot coupe<sup>®</sup>

New  
Register  
your product  
on line



**Blixer<sup>®</sup> 5 G • Blixer<sup>®</sup> 5 V.V. G • Blixer<sup>®</sup> 7 • Blixer<sup>®</sup> 7 V.V.**

# www.robot-coupe.com

## @ Register your product on line

The screenshot shows the Robot-Coupe website's support page. At the top, there is a navigation bar with the logo, a search bar, and links for 'The company', 'Contact us', 'Restricted Area', and 'Select your country...'. Below the navigation bar, the 'SUPPORT' menu item is highlighted. The main content area is divided into two columns. The left column is titled 'SUPPORT' and contains a section 'Register your product online'. This section includes a thank you message, a note that registration should take a few minutes, and a list of required information: product serial number and purchase date. A button labeled 'Register my product now' is at the bottom of this section. The right column is titled 'Access the Robot-Coupe after-sales service' and features an 'Authentication' form. The form includes a language selection dropdown, fields for 'Identifiant \*' and 'Mot de passe \*', a 'Mot de passe perdu' link, and an 'Email \*' field. A button labeled 'Access the Robot-Coupe after-sales service' is at the bottom of this section.

# robot coupe®

## EU Declaration of Conformity

**Robot-Coupe® SNC** declares that all the machines subject of these original instructions, as well as their accessories and their packaging, comply with:

- the essential requirements of the following European directives and with the corresponding national regulations :
  - Directive "Machinery" **2006/42/EC**,
  - Directive "Low Voltage" **2014/35/EU**,
  - Directive "Electromagnetic Compatibility" **2014/30/EU**,
  - Directive "Reduction of Hazardous Substances in Electrical Equipment" (RoHS) **2011/65/EU**,
  - Directive "Waste Electrical and Electronic Equipment" (WEEE) **2012/19/EU**,
- Regulation (EC) No **1907/2006** (latest consolidated version) «concerning the Registration, Evaluation, Authorisation and Restriction of Chemicals (REACH)» and as such, no product, accessory and their packaging sold by Robot-Coupe® SNC, contains any substance on the European Chemical Agency (ECHA) candidate list and considered of very high concern.
- Regulation (EC) No **1935/2004** «Materials and articles intended to come into contact with food» modified by regulation (EC) No 596/2009.
- Regulation (EC) No **2023/2006** «Good manufacturing practice for materials and articles intended to come into contact with food».
- Regulation (EU) No **10/2011** «Plastic materials and articles intended to come into contact with food», as well as all relevant (EU) regulations which modify, correct and/or rectify it, as at the date of this declaration, the regulations (EU) No 1282/2011, 1183/2012, 202/2014, 865/2014, 2015/174, 2016/1416, 2017/752, 2018/79, 2018/213, 2018/831 and 2019/37.
- the provisions of the following harmonized European standards and the standards specifying the safety and hygiene requirements:
  - **EN ISO 12100:2010** Safety of machinery – General principles for design,
  - **EN 60204-1:2006** Safety of machinery – Electrical equipment of machines,
  - **EN 60529** Degrees of protection provided by enclosures (IP Code):
    - IP 55 for the electric controls,
    - IP 34 for the other parts of the machine,
- and according to the category of the apparatus, with the provisions of the following harmonized European standards specifying the safety and hygiene requirements:
  - **EN 454** ..... Planetary Mixers,
  - **EN 1678** ..... Vegetable Cutting Machines (and Juice Extractors),
  - **EN 12852** ..... Food Processors and Blenders,
  - **EN 12853** ..... Hand-Held Blenders and Whisks (Power Mixers),
  - **EN 13208** ..... Vegetable Peelers,
  - **EN 13621** ..... Salad Dryers,
  - **EN 14655** ..... Baguette Slicers.

"R019"

Montceau-en-Bourgogne, on March 1<sup>st</sup>, 2019

Jean-Marie LOZANO  
Director of Industrial Operations



# SUMMARY

## ■ WARRANTY

## ■ IMPORTANT WARNING

## ■ INTRODUCTION TO YOUR NEW EMULSIFIER-MIXER Blixer® 5 G • Blixer® 5 V.V. G • Blixer® 7 • Blixer® 7 V.V.

## ■ SWITCHING ON THE MACHINE

- Advices on electrical connections
- Control panel
- Timer

## ■ ASSEMBLY

## ■ USES & EXAMPLES

## ■ HYGIENE

## ■ CLEANING

- Motor Base
- Bowl
- Blade
- Blixer® arm

## ■ MAINTENANCE

- Blade
- Blixer® arm
- Motor seal

## ■ TECHNICAL SPECIFICATIONS

- Weight
- Dimensions
- Working height
- Noise level
- Electrical data

## ■ OPERATION ERRORS

- List of errors displayed

## ■ SAFETY

## ■ STANDARDS

## ■ TECHNICAL DATA

- Electrical and wiring diagram

# ROBOT-COUPE S.N.C., LIMITED WARRANTY

Your new ROBOT-COUPE appliance is warranted to the original buyer for a period of one year from the date of sale if you bought it from ROBOT-COUPE S.N.C.

If you bought your ROBOT-COUPE product from a distributor your product is covered by your distributor's warranty (Please check with your distributor terms and conditions of the warranty).

The ROBOT-COUPE S.N.C. limited warranty is against defects in material and/or workmanship.

## THE FOLLOWING ARE NOT COVERED BY THE ROBOT-COUPE S.N.C. WARRANTY:

**1** - Damage caused by abuse, misuse, dropping, or other similar damage caused by or resulting from failure to follow assembly, operating, cleaning, user maintenance or storage instructions.

**2** - Labour to sharpen and/ or replacements for blades which have become blunt, chipped or worn after a normal or excessive period of use.

**3** - Materials or labour to replace or repair scratched, stained, chipped, pitted, dented or discoloured surfaces, blades, knives, attachments or accessories.

**4** - Any alteration, addition or repair that has not been carried out by the company or an approved service agency.

**5** - Transportation of the appliance to or from an approved service agency.

**6** - Labour charges to install or test new attachments or accessories (i.e., bowls, discs, blades, attachments) which have been arbitrarily replaced.

**7** - The cost of changing direction-of-rotation of electric motors (Installer is responsible).

**8** - SHIPPING DAMAGES. Visible and latent defects are the responsibility of the freight carrier. The consignee must inform the carrier and consignor immediately, or upon discovery in the case of latent defects.

KEEP ALL ORIGINAL CONTAINERS AND PACKING MATERIALS FOR CARRIER INSPECTION.

Neither ROBOT-COUPE S.N.C. nor its affiliated companies or any of its distributors, directors, agents, employees, or insurers will be liable for indirect damage, losses, or expenses linked to the appliance or the inability to use it.

The ROBOT-COUPE S.N.C. warranty is given expressly and in lieu of all other warranties, expressed or implied, for merchantability and for fitness toward a particular purpose and constitutes the only warranty made by ROBOT-COUPE S.N.C. France.

# RECOMMENDATIONS CONCERNING THE INSTALLATION OF VARIABLE-SPEED APPLIANCES AND PERSONAL SAFETY

These recommendations apply to machines equipped with an induction motor and a single-phase wobbulator.

## NB :

- The electrical circuit and the protective devices must comply with national regulations.
- The machine must be wired in by a qualified electrician

## Protecting your appliance

- Like all electronic devices, wobblators include components that are sensitive to electrostatic discharges (ESDs). Before conducting any work on these wobblators, technicians must therefore rid themselves of electrostatic charges.
- The machine must be disconnected from the mains supply before any internal connection operations are carried out.
- Repeatedly switching on the appliance will cause the wobbulator to overload and may result in its destruction. After the machine has been switched off, you must wait for 3 minutes before switching it back on again.

## Wiring

- The appliance requires single-phase current as far as the wobbulator, which turns the latter into variable-speed three-phase current to supply the motor.

- You must connect the machine to a 220 - 240 V / 50 or 60 Hz single-phase alternating current supply with an earthed socket. A higher voltage will destroy the wobbulator.
- The earthed socket ensures operator safety.

## Circuit interrupters ensuring user safety

Ground fault circuit interrupters (GFCIs) intended for variable-speed appliances need to be selected with great care in order to ensure operator safety. GFCIs may be sensitive to alternating current (type AC), impulse current (type A) or all currents (type B).

**Danger !** Wobblators feature a bridge-connected rectifier of the mains supply voltage. For this reason, in the event of an earth contact, a continuous fault current may fail to trip a differential circuit breaker that is only sensitive to alternating current (type AC).

As the appliance has a single-phase supply, it is therefore advisable to use a GFCI that is sensitive to impulse current (type A), identified by the following symbol: .

**Caution :** these GFCIs may go under different names, according to the manufacturer.

Appliances with wobblators produce a fault current on the earth wire. This current may be sufficient to trip the differential circuit breaker unnecessarily. This may occur if :

- Several variable-speed appliances are connected to the same GFCI.
- The appliance produces a fault current that is above the GFCI's actual trip threshold.

**Caution :** As there are manufacturing tolerances, the actual trip threshold of a GFCI will be between 50% and 100% of its theoretical nominal threshold. Should a problem arise, measure the fault current and the GFCI's actual trip threshold.

You can begin by consulting the characteristics of your appliance in the table below :

Appliance	Mains supply	Conductor Cross-section (mm <sup>2</sup> )	GFCI (Ph + N)	
			Gauge (A)	Threshold (mA)
Blixer® 5 V.V. Blixer® 7 V.V.	220 - 240V 50 or 60 Hz single-phase	2,5	B 20	≥ 30

# IMPORTANT WARNING



**WARNING:** In order to limit accidents such as electric shocks or personal injury, and in order to limit material damage due to misuse of the appliance, please read these instructions carefully and follow them strictly. Reading the operating instructions will help you get to know your appliance and enable you to use the equipment correctly. Please read these instructions in their entirety and make sure that anyone else who may use the appliance also reads them beforehand. Our equipment is designed for professional use and must not be used by children under any circumstances.

## UNPACKING

- Carefully remove the equipment from the packaging and take out all the boxes or packets containing attachments or specific items.
- **WARNING** - some of the tools are very sharp e.g. blade, discs...

## INSTALLATION

- We recommend you install your machine on a perfectly stable solid base.

## CONNECTION

- Always check that your mains supply corresponds to that indicated on the rating plate on the motor unit and that it can take the amperage.
- The machine must be earthed.
- With the three-phased version, always check that the blade rotates in an anti-clockwise direction.

## HANDLING

- Always take care when handling the blades or discs - they are very sharp.

## ASSEMBLY PROCEDURES

- Follow the various assembly procedures carefully (see page 8) and make sure that all the attachments are correctly positioned.

## USE

- Never try to override the locking and safety systems.
- Never introduce any object into the container where the food is being processed.
- Never push the ingredients down with your hand.
- Do not overload the appliance.
- Never switch the appliance on while it is empty.

## CLEANING

- As a precaution, always unplug your appliance before cleaning it.
- Always clean the appliance and its attachments at the end of each cycle.
- Never place the motor unit in water.
- For parts made of aluminum alloys, use cleaning fluids suitable for aluminum.

- For plastic parts, do not use detergents that are too alkaline (i.e., containing too much caustic soda or ammonia...).
- Robot-Coupe can in no way be held responsible for the user's failure to follow the basic rules of cleaning and hygiene.

## MAINTENANCE

- Before opening the motor housing, it is absolutely vital unplug the appliance.
- Check the seals and washers regularly and ensure that the safety devices are in good working order.
- It is particularly important to maintain and check the attachments since certain ingredients contain corrosive agents e.g. citric acid.
- Never operate the appliance if the power cord or plug has been damaged in any way or if the appliance fails to work properly or has been damaged in any way.
- Do not hesitate to contact your local Maintenance Department if something appears to be wrong.

## INTRODUCTION TO YOUR NEW Blixer® 5 G • Blixer® 5 V.V. G • Blixer® 7 • Blixer® 7 V.V. TABLE- TOP CUTTER MIXER

ROBOT-COUPE has developed a new concept in appliance: the **Blixer®**.

The Blixer® combines the features of two well-known appliances: the cutter and the blender-mixer.

The Blixer® is perfectly geared to professional needs. It can perform any number of tasks which you will soon discover as you use it.

The Blixer® will make it easy to prepare mixed liquid or semi-liquid, raw or cooked meals.

The Blixer® replace the blender which does not give entire satisfaction because of its incapacity to process solid foods.

Thanks to its simple design, all components requiring frequent handling for maintenance or cleaning are easily fitted or removed.

To make things easier for you, this manual gives a breakdown of all the various fitting operations.

This manual contains important information designed to help the user get the most out of their device.

**We therefore recommend that you read it carefully before using your machine.**

## SWITCHING ON THE MACHINE

### • ADVICE ON ELECTRICAL CONNECTIONS

Before plugging in, check that your power supply corresponds to that indicated on the machine's identification plate.



## WARNING

**This appliance must be plugged into an earthed socket (risk of electrocution).**

### • Blixer® 5 • Blixer® 7 Three phase

ROBOT-COUPE appliances are fitted with the following types of motor:

230-400 V / 50 Hz / 3

400 V / 50 Hz / 3

220 V / 60 Hz / 3

380 V / 60 Hz / 3

This machine is supplied with a cable to which you simply attach the appropriate electrical plug or isolator for your system. The cable has four wires, one earth wire, plus three phases wires.

### If you have a 4-pin plug:

- 1) Connect the green and yellow earth wire to the earth pin.
- 2) Connect the three other wires to the remaining pins.

**If you have more than 4 pins in the plug**, please note the ROBOT-COUPE does not require a neutral wire.

**Switch on the empty machine, making sure that the blade is rotating properly in an anti-clockwise direction.**

On the motor unit and on the lid a arrow marks the blade rotation directions.

If the blade turns in a clockwise direction, swap over two wires.

**GREEN YELLOW is the earth,  
DO NOT DISCONNECT**

Swap either : the ❶ and the ❷  
the ❷ and the ❸  
the ❶ and the ❸

### • Blixer® 5 Single phase

ROBOT-COUPE appliances are fitted with the following types of moto:

230 V / 50 Hz / 1

220 V / 60 Hz / 1

The machine comes with a single phase plug connected to a power cord.

### • Blixer® 5 V.V. • Blixer® 7 V.V. Single phase

The models are available with a single phase motor: + variable speed: 230 V / 50 - 60 Hz / 1

The standardized plug must be calibrated to a minimum of 16 amps and preferably 20 amps, if the appliance is used intensively.

### • ENERGY SAVING MODE FOR Blixer® 5 - Blixer® 7

After the food processor is plugged in, it needs to be switched on by pressing the "on" button I.

If the processor is not used for 5 minutes, it will go into energy saving mode.

The "on" button needs to be pressed again to switch on the power supply.

### • CONTROL PANEL

Red switch = Off switch

Green switch I = Start speed 1

Black switch = Pulse control

### Blixer® 5 - Blixer® 7 :

Green switch II = Start speed 2

### Blixer® 5 V.V. - Blixer® 7 V.V. :

Speed variation from 300 to 3,500 rpm.

## • TIMER

### How the timer works

The timer has three 7-segment LED displays, two timer adjustment buttons and a buzzer.

#### a) Countdown

When the food processor is switched on, the timer usually displays **0.00** and can be set directly. This is called Countdown Mode. The timer increments one second at a time when the motor is operating. Incrementation stops if the motor stops then resumes when the motor starts again. In the case of models Blixer® 5 V.V. and Blixer® 7 V.V., the food processor automatically stops after 9 minutes and the timer stops. In the case of models Blixer® 5 and Blixer® 7, the food processor automatically stops after 5 minutes and the timer stops.

#### b) Timer

Before starting, the user can adjust the processing time to anywhere between **0.05** (5 seconds) and **9.00** (9 minutes) by pressing the + and – buttons. When the motor starts, the timer increments one second at a time. This is called Timer Mode. Countdown stops if the motor stops and resumes when the motor starts again. When the countdown gets to **0.00**, the processor stops and a buzzer sounds. The time initially set is then displayed again.

#### c) Starting the processor with the Pulse button:

If the food processor is started using the Pulse button, the timer goes into Countdown Mode when the Pulse button is held down and returns to the previous timer display when the Pulse button is released.

#### d) Reset

If the timer displays anything other than **0.00** when the motor is not operating, the user can reset the display to zero by pressing the + and – buttons at the same time or by pressing the “off” button on the food processor for 2 seconds.

#### e) Standby Mode

If the food processor is not used for more than 10 minutes (motor not operating), the timer goes into Standby Mode. Standby Mode can be cancelled by pressing any button or the “on” button.

#### f) Turning off the timer:

If you do not want to use the timer, you can deactivate it by pressing the “on” and “off” buttons at the same time for several seconds.

Repeat the operation to reactivate the timer function.



2) Engage the blade on the motor shaft and lower it right to the bottom of the bowl.

Make sure that it is correctly positioned, by rotating it in the bowl.



## ASSEMBLY

1) With the motor base facing you, position the cutter bowl on the motor base.

Turn the bowl to the right until it locks.



3) Put the lid equipped with the Blixer® arm on the bowl (see page 10) and turn to the right until locked in place.

The device is now ready for use.

## USES & EXAMPLES

The Blixer® will enable you to perform all your cutting tasks in minimum time, we recommend therefore, that you keep a close eye on the mixture in order to obtain the desired results.

### HOSPITAL USES

#### SPOON FEEDING

- Minced foods: meat, fish...
- Vegetable purees
- Mousses: vegetables, fish...
- Compotes of stewed fruit

#### SEMI-LIQUID FEEDING

This simply entails diluting spoon-feeding preparations:

- Minced meat + gravy
- Puree + liquid (broth, milk...)
- Soups / creamed soups
- Fruit compotes + syrup or water

#### LIQUID FEEDING (for use via tubes)

- Soups and any preparations that can be liquidized.

### RESTAURANTS AND DELICATESSEN USES

- Butter mixtures: snail butter, salmon butter, anchovie butter...
- Sauces: green sauce, mayonnaise, remoulade, ailloli, emulsify sauces with tomatoes, cream, parsley...
- Grinding: lobster, scampi, seashells...

## PHARMACEUTICAL AND CHEMICAL LABORATORY USES

- Grinding: herbs, seeds, powders, tablets....
- Mixing: homogeneization of creams, ointments, mixed components, varied ingredients...

## HYGIENE

At each step of food processing, the machine and attachments must be clean.

A certain order when processing foods must be followed. In general, always try to process foods that are least likely to cause cross-contamination first, as illustrated in the following example :

- 1 - Cooked meat
  - Terrines/mousses
  - Delicatessen
    - ham
    - smoked ham
    - sausage.
- 2 - Cheese
  - hard
  - other type.
- 3 - Vegetables.

It is vital that all parts of the machine that come into contact with food are cleaned meticulously, using a detergent/sanitiser, after each processing job.

### • WARNING: NEVER USE PURE BLEACH.

Always follow the detergent manufacturers instructions to make up the correct strength of solution; these are normally found on the detergent package, if in doubt contact your detergent supplier or manufacturer.

- If necessary rub well with a soft brush or cloth: NEVER use a harsh abrasive cleaning pad.

- Allow the detergent/sanitiser to work for the required length of time.
- Always rinse well.
- Dry well with a soft clean cloth. Only air dry if the detergent manufacturer recommends it.

## CLEANING



## WARNING

As a precaution, always unplug your appliance before cleaning it (risk of electrocution).

### • MOTOR BASE

Never immerse the motor base in water. Clean using a damp cloth or sponge.

### • BOWL

After removing the lid, remove the bowl from the motor base by pushing the trigger fitted in the handle. Pull up to disengage, leaving the blade in the bowl in order to prevent any spillage when working with liquids.

If the food has a solid consistency, remove the blade and empty the bowl.

Replace the bowl, place the blade back on the shaft and switch on the machine in order to remove any mixture which may have stuck to the blade.

If you wish, you can rinse the bowl by filling it with hot water and switching on for a few minutes.

### • BLADE

The stainless steel blade of Blixer® 7 and Blixer® 7 V.V. is easy to dismantle and to clean.

After cleaning the blade, always dry the blades well to prevent rusting.

## The blade must always be removed for cleaning

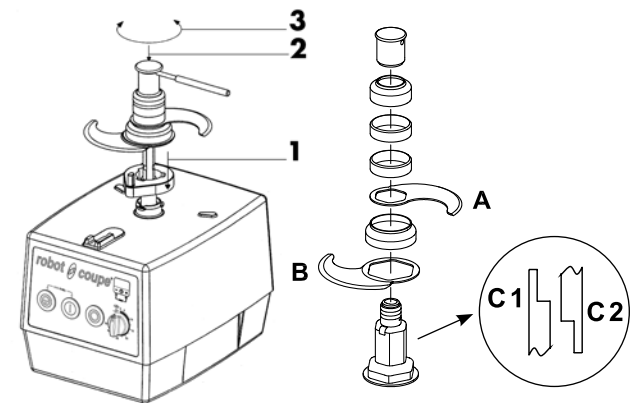

Ensure power supply to machine is disconnected.

- 1 - Place blade dismantling tool over shaft onto motor base.
- 2 - Place blade on shaft.
- 3 - Place dismantling tool in hole over blade nut and turn anti-clockwise to unscrew. To remount, carry out operation in reverse. In both cases, blade is supported by small knob on blade dismantling tool.

A - Upper blade with sharp edge away from you.

B - Lower blade with sharp edge towards you.

C - Depending on space required between blades during reassembly, assemble spacers C as follows:

C1 if spacer is placed above blade

C2 if spacer is placed below blade.

## • BLIXER® ARM

To clean the Blixer® arm, dismount as follows:

Hold the Blixer® arm in one hand and the middle of the blade in the other (drawing 1).

Press the two pieces together and turn the handle 45° anticlockwise (drawing 2).

The two parts of the Blixer® arm can then be removed from the lid for cleaning (drawing 3).

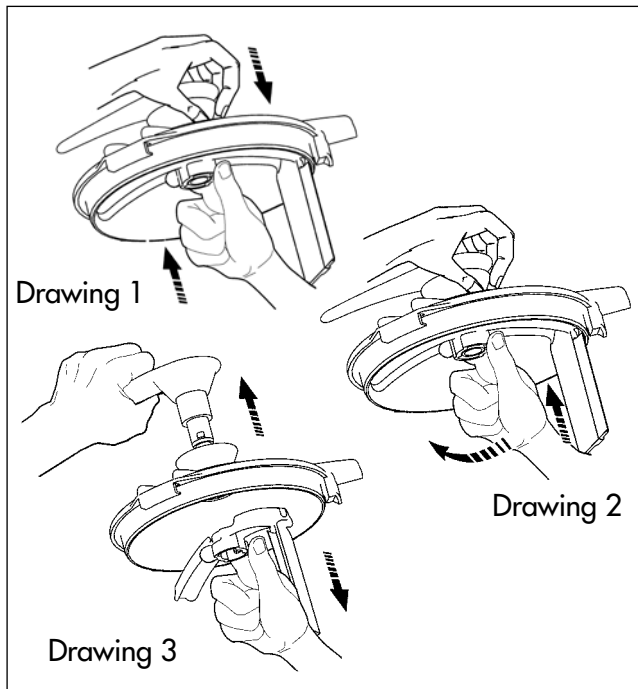

## IMPORTANT

Check that your detergent is suitable for cleaning plastic parts. Some washing agents are too alkaline (e.g. high levels of caustic soda or ammonia) and totally incompatible with certain types of plastic, causing them to deteriorate rapidly.

## MAINTENANCE

### • BLADE

The cutting quality mainly depends on the sharpness of the blades and degree of wear. The blades are wearing parts which should be changed from time to time to ensure consistent quality of the end product.

### • BLIXER® ARM

The Blixer® arm has rubber pieces which are wearing parts. They must therefore be periodically replaced to maintain optimum efficiency of the arm.

The rubber pieces are very easy to remove and remount.

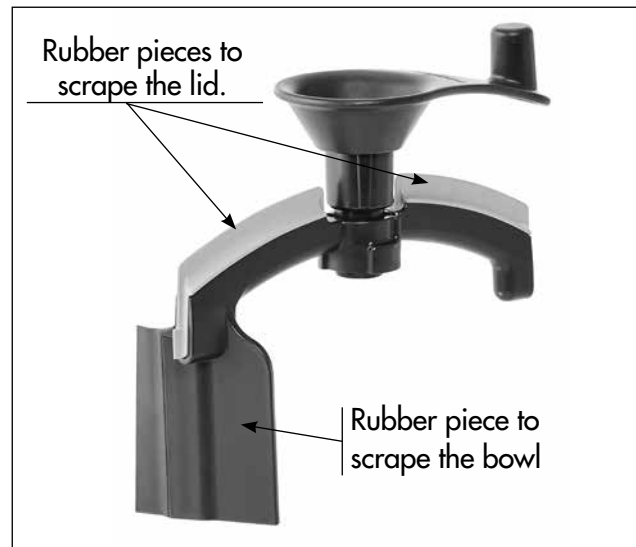

### • MOTOR SEAL

In order to keep the motor completely watertight, it is advisable to check the motor seal regularly for wear and tear and replace if necessary.

The seal must be replaced once a year and once every 6 months in the case of intensive use.

The motor seal can be easily replaced without having to remove the motor, so we strongly advise you to ensure that is in good condition.

## TECHNICAL SPECIFICATIONS

### • WEIGHT

	Net	Gross
Blixer® 5 G	21.0 kg	23.5 kg
Blixer® 5 V.V. G	21.5 kg	24.0 kg
Blixer® 7	22.5 kg	25.0 kg
Blixer® 7 V.V.	22.5 kg	25.0 kg

### • DIMENSIONS (in mm)

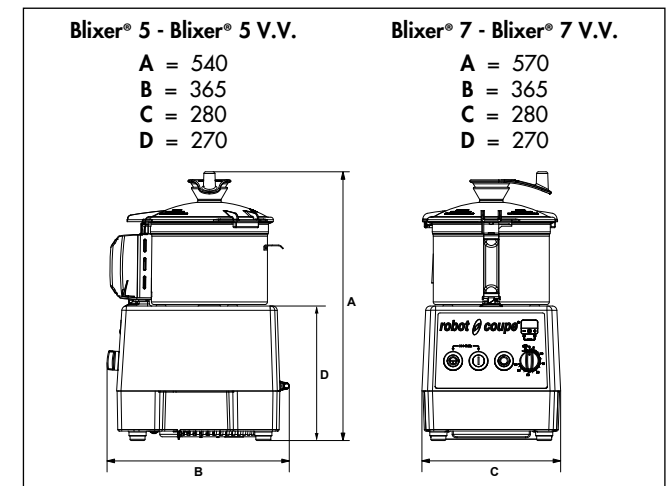

### • WORKING HEIGHT

We recommend that you position the machine on a stable worktop so that the upper edge of the large feed hopper is at a height of between 1.20 m and 1.30 m.

• **NOISE LEVEL**

The equivalent continuous sound level when the machine is operating on no-load is less than 70 db (A).

• **ELECTRICAL DATA**

Blixer® 5 three-phase machine

Motor	Speed 1 (rpm)	Speed 2 (rpm)	Intensity (Amp)
230 x 400 V / 50 Hz	1,500		230V = 4.0 400V = 2.5
		3,000	230V = 7.0 400V = 4.0
400 V / 50 Hz	1,500		2.7
		3,000	3.4
220 V / 60 Hz	1,800		4.7
		3,600	6.5
380 V / 60 Hz	1,800		2.5
		3,600	3.4

Blixer® 5 single-phase machine

Motor	Speed (rpm)	Intensity (Amp)
230 V / 50 Hz	3,000	8.7
220 V / 60 Hz	3,600	9.5

Blixer® 5 V.V. single-phase machine

Motor	Speed (rpm)	Intensity (Amp)
230-120 V / 50-60 Hz	300 to 3500	5.8

Blixer® 7 three-phase machine

Motor	Speed 1 (rpm)	Speed 2 (rpm)	Intensity (Amp)
230 x 400 V / 50 Hz	1,500		230V = 4.0 400V = 2.5
		3,000	230V = 7.0 400V = 4.0
400 V / 50 Hz	1,500		2.7
		3,000	3.4

Blixer® 7 single-phase machine

Motor	Speed (rpm)	Intensity (Amp)
230-120 V / 50-60 Hz	300 to 3500	5.8

- Power shown on data plate.

**SAFETY**

 **WARNING**

The blades are sharp and must be handled with care.

These models are fitted with a magnetic safety device and motor braking system.

As soon as you open the lid the motor stops.

To restart the machine, simply close the lid and press the green switch.

In order to avoid splashing when processing liquid preparation, we recommend you stop the machine before opening the lid.

All the models are fitted with a **thermal cut-out** which automatically stops the motor if the machine is left on for too long or overloaded.

If this happens, allow the machine to cool completely before restarting.

 **REMEMBER**

**Never try to override the locking and safety systems.**

**Never insert an object into the container where the food is being processed.**

**Never push the ingredients down with your hand.**

**Do not overload the appliance.**

**Never switch the appliance on when it is empty.**

**OPERATION ERRORS**

• **LIST OF ERRORS DISPLAYED**

- Blixer 5 V.V. G • Blixer 7 V.V.  
(single-phase variable speed appliances)

Message	Description	Solution
E01	Motor over-load	Press Stop button . Start the machine again, reducing the load if necessary. If the problem persists, contact After-Sales
E02	Overvoltage	Restart the machine. If the problem persists, contact After-Sales
E03	Undervoltage	Restart the machine. If the problem persists, contact After-Sales
E08	Thermal failsafe triggered on AC drive	Let the machine cool down. Check that the vents under the motor base are not obstructed. If necessary, reduce the operating load.
E09	Safety systems	Press Stop button . If the problem persists, contact After-Sales
E12	Thermal failsafe triggered on motor	Check the stop button is not stuck or let the machine cool down for 20 minutes.
E13	During stopping of machine	A start attempt was made while the machine was stopping. Wait until the motor has stopped completely before starting again

Message	Description	Solution
E14	Checking of safety systems	The safety switches are not closed properly. Check that the protectors (lid, pushers, lid lock, etc.) are in the correct position.
<b>Other Message or Persistent Message</b>		<b>Contact After-Sales.</b>

### - Blixer 5 G • Blixer 7 (three-phase appliances)

Message	Description	Solution
E06	Thermal failsafe	The temperature inside the motor base is too high. Turn off the machine and let it cool. Check that the vents under the base are not obstructed.
E08	Position of control buttons	The control buttons are not in the right position. Check that none of them are stuck.
E09	Thermal failsafe triggered on motor	Turn off the machine and let it cool. Check that the vents under the base are not obstructed. If necessary, reduce the operating load.
E10	Position of stop button	The contact for the stop button is not closed. Release the button. Check that it is not stuck.
E11	Checking of safety systems	Remove the parts indicated and put them back in place to reset the safety systems.

E12	Checking of bowl safety system	Remove the bowl and put it back in place to reset the safety system.
E13	Checking of pusher safety system on veg cutter	Open and close the lever on the large feed head to make sure it is properly positioned. Remove the pushers from the feed heads and put them back in place to reset the safety systems.
E14	Checking of lid safety system on veg cutter	Open then close the veg cutter lid lock to reset the safety system.
E16	Machine needs to be reset	Disconnect the machine then turn the power on again to reset. If the problem persists, have the timer checked by After-Sales.
<b>Other Message or Persistent Message</b>		<b>Contact After-Sales.</b>

### - Blixer 5 G - 1V (single-phase appliance)

Message	Description	Solution
E06	Thermal failsafe	The temperature inside the motor base is too high. Turn off the machine and let it cool. Check that the vents under the base are not obstructed.
E08	Position of control buttons	The control buttons are not in the right position. Check that none of them are stuck.
E09	Thermal failsafe triggered on motor	Turn off the machine and let it cool. Check that the vents under the base are not obstructed. If necessary, reduce the operating load.

E10	Position of stop button	The contact for the stop button is not closed. Release the button. Check that it is not stuck.
E12	Checking of bowl and lid safety systems	Remove the bowl and lid and put them back in place to reset the safety systems.
E16	Machine needs to be reset	Disconnect the machine then turn the power on again to reset. If the problem persists, have the timer checked by an approved Robot-Coupe technical service.
<b>Other Message or Persistent Message</b>		<b>Contact After-Sales.</b>

## STANDARDS

Consult the declaration of compliance on page 2.

*robot*  *coupe*®

**TECHNICAL DATA**

# BLIXER 5 G - BLIXER 7 - R 5 G - R 7 - R 502 G - R 752

200V, 230V, 400V/50Hz - 220V, 380V, 440V/60Hz - 3~

## SCHEMA ELECTRIQUE

## ELECTRIC DIAGRAM

## ELEKTRISCHES SCHALTBILD



Vérifier que le fil d'adaptation à la tension de votre réseau est correctement positionné (voir tableau ci-dessous).  
Check that the wire which allows the adaptation to the supply voltage is on the right terminal (see table below).  
Unbedingt prüfen, ob der Draht zur Anpassung an die Spannung Ihres Stromnetzes Korrekt positioniert ist (siehe Tabelle unten).

Vérifier le sens de rotation.  
Check direction of rotation.  
Drehrichtung prüfen.

	Français	English	Deutsch
BPA	Bouton poussoir ARRET	OFF switch	Stoppsschalter
BV1	Bouton poussoir MARCHE Vitesse 1	Low speed switch	NiedrigerGeschwindigkeit-Druckknopf
BV2	Bouton poussoir MARCHE Vitesse 2	High speed switch	Hochgeschwindigkeits-Druckknopf
BPP	Bouton poussoir PULSE	PULSE switch	Impulsschalter
ISCL	Interrupteur de Sécurité Poussoir Coupe-Légumes	Pusher safety switch Vegetable slicer	Sicherheitsschalter Stössel Gemüseschneider
ISCO	Interrupteur de Sécurité Couvercle Coupe-légumes	Feed lead safety switch Vegetable slicer	DeckelSicherheitsschalter Gemüseschneider
ISCU	Interrupteur de Sécurité Cutter	Cutter lid safety switch	Sicherheitsschalter Messerdeckel
MI	Minuterie	Timer	Timer
MO	Moteur	Motor	Motor
P	Carte de commande réf 49484/114600	Control Board ref 49484/114600	Steuerplatine Numer 49484/114600
PTO	Protecteur thermique intégré au moteur	Thermal protector integrated in the motor	Thermoschutz im Motor integriert

**A partir de / From / Von**  
**Blixer 5 G** ..... : M82001111XX  
**Blixer 7** ..... : M82601111XX  
**R 5 G** ..... : M81701111XX  
**R 7** ..... : M82401111XX  
**R 502 G** ..... : M81401111XX  
**R 752** ..... : M82201111XX

**Interrupteurs de sécurité et configuration**  
**Safety switches and configuration**  
**Sicherheitsschalter und Konfiguration**

C	Machine Maschine	ISCL	ISCO	ISCU
C1	R 502 G	✓	✓	
	R 752			
C3	BLIXER 5 G			✓
	BLIXER 7	*	*	
	R 5 G			
	R 7			

\* Non utilisé / Not used / Nicht Benutzt

**C Configuration - Konfiguration**

Utiliser le cavalier de configuration adapté à la machine.  
Use the correct configuration jumper for the machine.  
Verwenden Sie die richtige Konfiguration Brücke für die Maschine.

**Combinés** C1

**Cutter-Blixer** C3

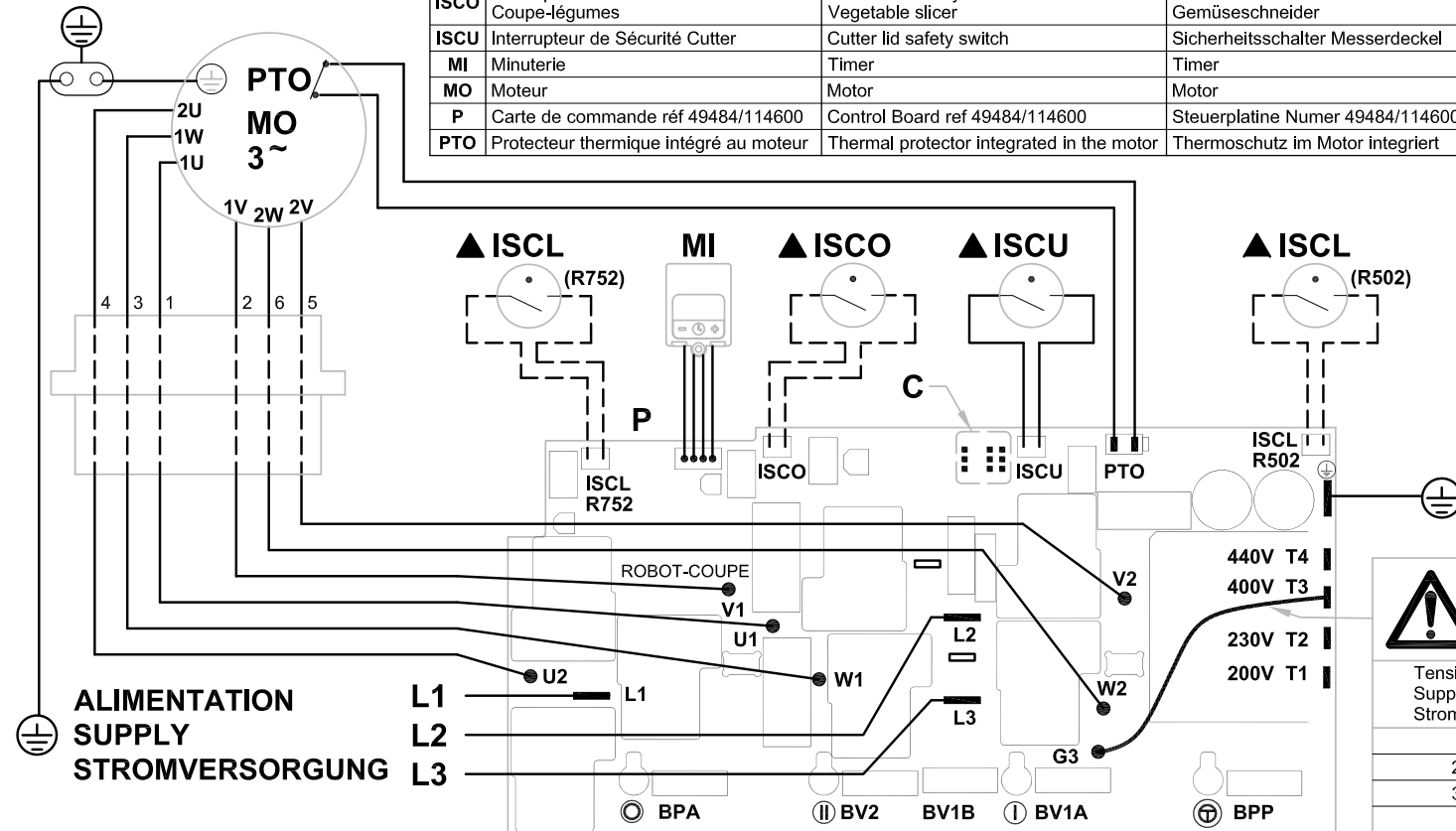

**A commuter suivant la tension d'allimentation.**  
**For switching according to supply voltage.**  
**Umschalten gemäß der Stromspannung.**

Tension d'alimentation Supply voltage Stromspannung	Connexion Terminal Anschluss
200 V	200 (T1)
220 -> 240 V	230 (T2)
380 -> 415 V	400 (T3)
440 V	440 (T4)

R 5 V.V.G - R 7 V.V. - Blixer® 5 V.V.G - Blixer® 7 V.V. - R 502 V.V.G - R 752 V.V.

200-240V/50-60Hz 1~

SCHEMA ELECTRIQUE

ELECTRIC DIAGRAM

ELEKTRISCHES SCHALTBILD

	Français	English	Deutsch
BPA	Bouton poussoir ARRET	OFF switch	Stopschalter
BPM	Bouton poussoir MARCHE	ON switch	Betriebsschalter
BPP	Bouton poussoir PULSE	PULSE switch	Impulsschalter
CB	Carte boutons réf. 49468	Switches card ref. 49468	Schalteren Karte. Numer 49468
CC	Carte capteur vitesse réf. 102920S	Speed sensor circuit ref. 102920S	Kaptor Karte. Numer 102920S
ISCL R 502	Interrupteur de Sécurité Poussoir Coupe-Légumes	Pusher safety switch vegetable slicer	Sicherheitsschalter Stössel Gemüseschneider
ISCL R 752	Interrupteur de Sécurité Poussoir Coupe-Légumes	Pusher safety switch vegetable slicer	Sicherheitsschalter Stössel Gemüseschneider
ISCO	Interrupteur de Sécurité Couvercle Coupe-légumes	Feed lead safety switch vegetable slicer	Sicherheitsschalter Deckel Gemüseschneider
ISCU	Interrupteur de Sécurité Cutter	Cutter lid safety switch	Sicherheitsschalter Messerdeckel
MI	Minuterie	Timer	Timer
MO	Moteur	Motor	Motor
V	Variateur réf. 39972	Variator ref. 39972	Variator Numer 39972
PTO	Protecteur thermique intégré au moteur	Thermal protector integrated in the motor	Thermoschutz im Motor integriert

▲ Interrupteurs de sécurité Safety switches Sicherheitsschalter			
	ISCL	ISCO	ISCU
R 502 V.V.G	✓	✓	
R 752 V.V.			✓
BLIXER 5 V.V.G	*	*	
BLIXER 7 V.V.			✓
R 5 V.V.G	*	*	
R 7 V.V.			

\* Non utilisé  
Not used / Nicht Benutzt

▲ **Vérifier le sens de rotation.**  
**Check drive shaft rotation.**  
**Drehrichtung prüfen.**

**A partir de / From / Von**  
**R5 V.V. G ..... : M8180111101**  
**R7 V.V. .... : M8250111101**  
**Blixer 5 V.V.G : M8210111101**  
**Blixer 7 V.V. .... : M8270111101**  
**R502 V.V.G ..... : M8150111101**  
**R752 V.V. .... : M8230111101**

**ALIMENTATION  
SUPPLY  
STROMVERSORGUNG**

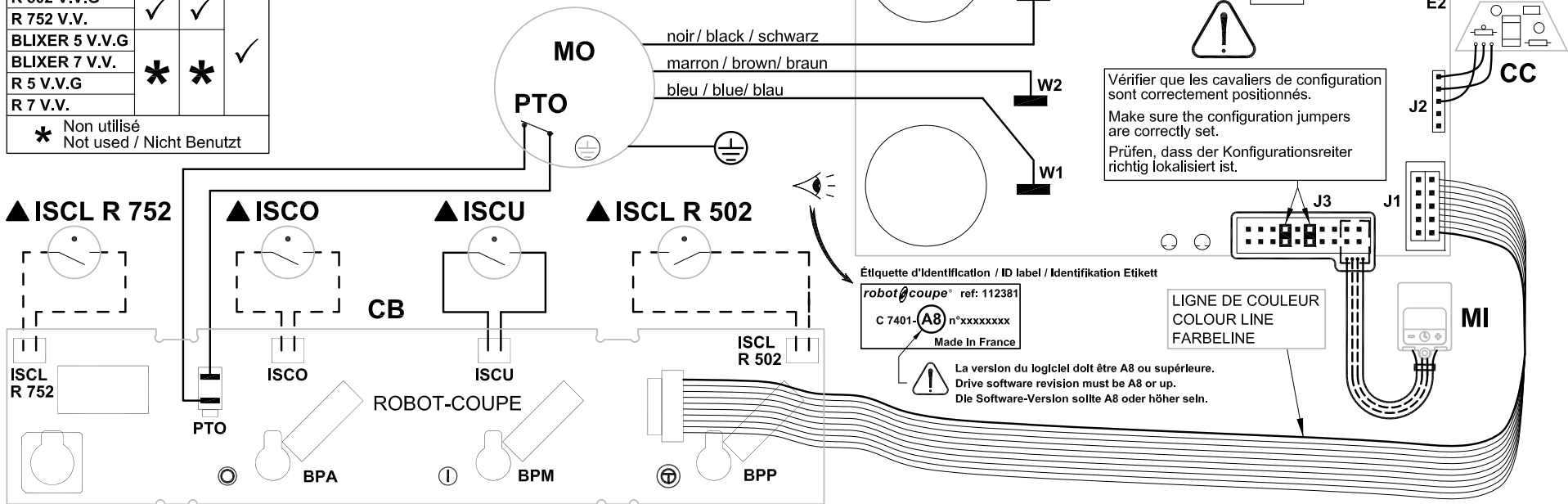



**robot coupe®**

**Head Office, French,  
Export and Marketing Department:**  
48, rue des Vignerons  
94305 Vincennes Cedex- France  
Tel.: 01 43 98 88 15  
Email: [international@robot-coupe.com](mailto:international@robot-coupe.com)

**Robot Coupe  
Australia Pty Ltd:**  
Unit 3/43 Herbert St  
Artarmon NSW 2064 Australia  
Tel.: (02) 9478 0300  
Email: [orders@robotcoupe.com.au](mailto:orders@robotcoupe.com.au)

**Robot-Coupe  
U.K. LTD:**  
Fleming Way, Isleworth,  
Middlesex TW7 6EU  
Tel.: 020 8232 1800  
Email: [sales@robotcoupe.co.uk](mailto:sales@robotcoupe.co.uk)



37002314451663

Réf. : 451 663 - 17/11/2021