



VACUUM PACKING MACHINE SU-420+ 230/50-60/1

Tabletop model. 20 m³/h. 420 mm.



P/N 1140775



FEATURES AND BENEFITS

- ✓ Powered by Busch.
- ✓ Vacuum controlled by sensor.
- ✓ Vacuum PLUS.
- ✓ LCD colour screen: all information at a glance.
- ✓ Backlit touch keyboard.
- ✓ Programmable: 25-programme memory. Blocking option.
- ✓ "Pause" button.
- ✓ Phased vacuum programme.
- ✓ Detection of the evaporation of liquids.
- ✓ Double seal.
- ✓ Cordless sealing bar.
- ✓ Progressive decompression.
- ✓ Vac-Norm ready with Automatic decompression.
- ✓ Stainless steel body and chamber. Deep-drawn chamber.
- ✓ Damped transparent lid of high durability polycarbonate.
- ✓ Dry-oil programme for drying the pump.
- ✓ Working hours counter for oil changes.
- ✓ Safety system with protection against vacuum failure.

SALES DESCRIPTION

- 420 mm. sealing bar.
- 20 m³/h Busch vacuum pump.
- Vacuum controlled by sensor.

INCLUDES

- ✓ Filling plate
- ✓ "Plus" sealing system

ACCESSORIES

- Bag cutting kits
- Filling plates
- Liquid insert plates
- Vac-norm external vacuum kits
- Vac-norm containers
- Smooth bags for vacuum packing
- Trolley for vacuum packing machines
- CG2 Desktop printer for SU vacuum packing machines *
- Thermal labels for CG2 printer



www.sammic.co.uk

Food Service Equipment Manufacturer

Unit 2, Trevanah Road
Troon Industrial Park
LE4 9LS - Leicester

uksales@sammic.com
Tel.: +44 0116 246 1900



Project

Date

Item

Qty

Approved

FOOD PRESERVATION AND SOUS-VIDE
VACUUM PACKING MACHINES - "SENSOR ULTRA" LINE

product sheet
updated 01/08/2018



VACUUM PACKING MACHINE SU-420+ 230/50-60/1

Tabletop model. 20 m³/h. 420 mm.



P/N 1140775

SPECIFICATIONS

Pump capacity: 20 m³/h
 Bar length: 420 mm
 Total loading: 750 W
 Vacuum pressure (maximum): 2 mbar
 Electrical supply: 230 V / 50-60 Hz / 1 ~
 (5.5 A)

Internal dimensions

- ✓ Width: 430 mm
- ✓ Depth: 415 mm
- ✓ Height: 180 mm

External dimensions (WxDxH)

- ✓ Width: 484 mm
 - ✓ Depth: 529 mm
 - ✓ Height: 448 mm
- Net weight: 70 Kg
 Noise level (1m.): 75 dB(A)
 Background noise: 32 dB(A)

Crated dimensions

600 x 600 x 620 mm
 Gross weight: 63 Kg.

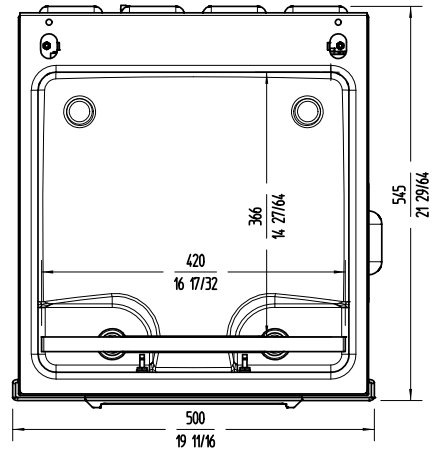
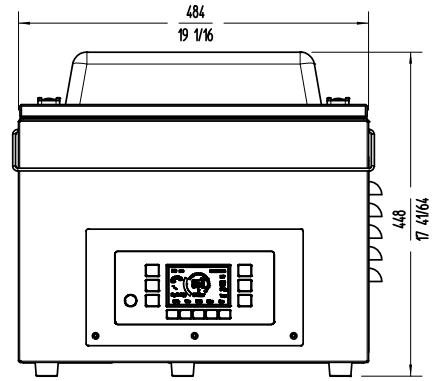
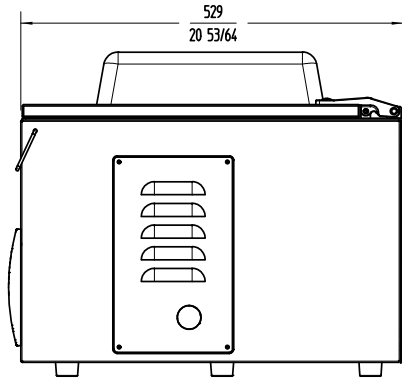

FOOD PRESERVATION AND SOUS-VIDE
 VACUUM PACKING MACHINES - "SENSOR ULTRA" LINE



www.sammic.co.uk
 Food Service Equipment Manufacturer
 Unit 2, Trevanth Road
 Troon Industrial Park
 LE4 9LS - Leicester
 uksales@sammic.com
 Tel.: +44 0116 246 1900



Project	Date
Item	Qty
Approved	