



VACUUM PACKING MACHINE SU-604 230-400/50/3N

Floorstanding unit. 40 m³/h. 413+656 mm.



P/N 1140811



FEATURES AND BENEFITS

- ✓ Powered by Busch.
- ✓ Vacuum controlled by sensor.
- ✓ Vacuum PLUS.
- ✓ LCD colour screen: all information at a glance.
- ✓ Backlit touch keyboard.
- ✓ Programmable: 25-programme memory. Blocking option.
- ✓ "Pause" button.
- ✓ Phased vacuum programme.
- ✓ Detection of the evaporation of liquids.
- ✓ Double seal.
- ✓ Cordless sealing bar.
- ✓ Progressive decompression.
- ✓ Vac-Norm ready with Automatic decompression.
- ✓ Stainless steel body and chamber.
- ✓ Damped transparent lid of high durability polycarbonate.
- ✓ Dry-oil programme for drying the pump.
- ✓ Working hours counter for oil changes.
- ✓ Safety system with protection against vacuum failure.
- ✓ NSF-listed.

SALES DESCRIPTION

- Two sealing bars (413+656 mm.)
- 40 m³/h Busch vacuum pump.
- Vacuum controlled by sensor.

INCLUDES

- ✓ BUSCH pump.
- ✓ Sensor Controls.
- ✓ 25 programmable settings.
- ✓ Vacuum PLUS: up to 10 seconds of extra vacuum pull.
- ✓ Soft air function.
- ✓ Clear methacrylate lid.
- ✓ "PAUSE" function.
- ✓ Liquid detection system.
- ✓ Dry oil cycle.
- ✓ NSF Approved.
- ✓ Filling plate.

ACCESSORIES

- Bag cutting kits
- Filling plates
- Liquid insert plates
- Vac-norm external vacuum kits
- Vac-norm containers
- Smooth bags for vacuum packing
- CG2 Desktop printer for SU vacuum packing machines *
- Thermal labels for CG2 printer

FOOD PRESERVATION AND SOUS-VIDE
VACUUM PACKING MACHINES - "SENSOR ULTRA" LINE



www.sammic.co.uk

Food Service Equipment Manufacturer

Unit 2, Trevanth Road
Troon Industrial Park
LE4 9LS - Leicester

uksales@sammic.com
Tel.: +44 0116 246 1900



Project	Date
Item	Qty
Approved	

product sheet
updated 01/08/2018



VACUUM PACKING MACHINE SU-604 230-400/50/3N

Floorstanding unit. 40 m³/h. 413+656 mm.



P/N 1140811

SPECIFICATIONS

Pump capacity: 40 m³/h
 Bar length: 413 mm + 656 mm
 Total loading: 1100 W
 Vacuum pressure (maximum): 0.5 mbar
 Electrical supply: 400 V-230 V / 50 Hz / 3N
 ~ (3.5 A)

Internal dimensions

- ✓ Width: 672 mm
- ✓ Depth: 481 mm
- ✓ Height: 200 mm

External dimensions (WxDxH)

- ✓ Width: 740 mm
- ✓ Depth: 566 mm
- ✓ Height: 997 mm

Net weight: 145 Kg

Noise level (1m.): 75 dB(A)

Background noise: 32 dB(A)

Crated dimensions

670 x 830 x 1200 mm

Gross weight: 170.5 Kg.

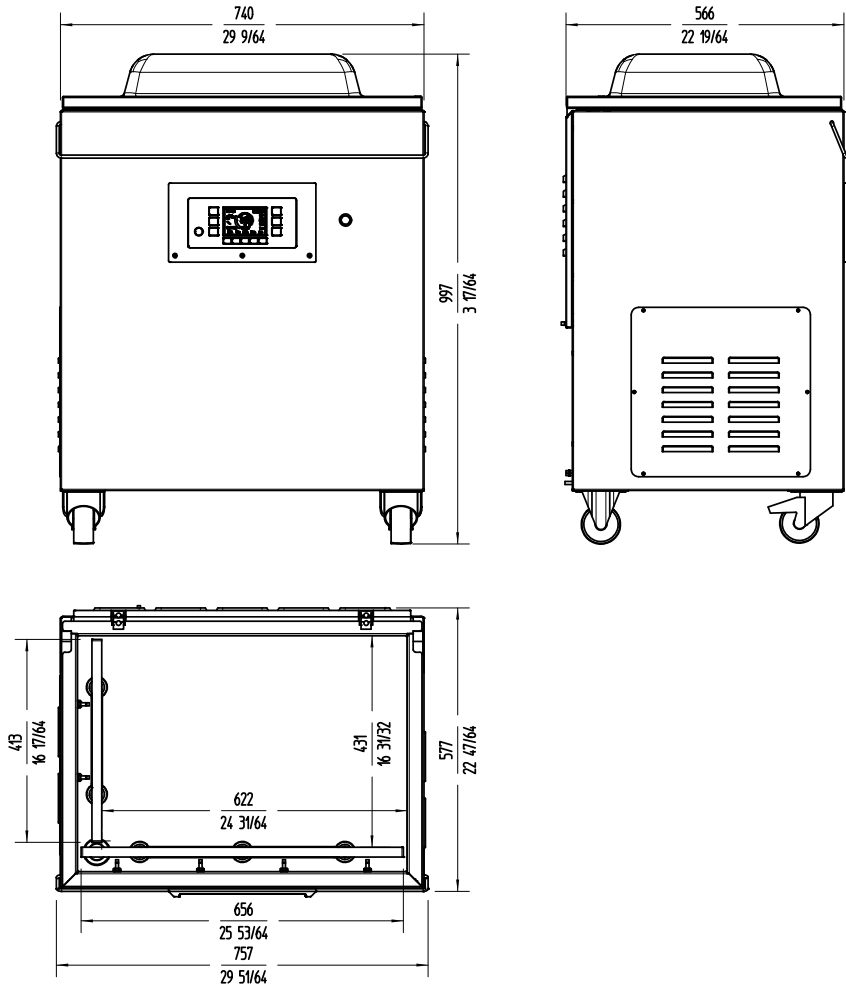

FOOD PRESERVATION AND SOUS-VIDE
VACUUM PACKING MACHINES - "SENSOR ULTRA" LINE



www.sammic.co.uk

Food Service Equipment Manufacturer

Unit 2, Trevanah Road
Troon Industrial Park
LE4 9LS - Leicester

uksales@sammic.com
Tel.: +44 0116 246 1900



Project	Date
Item	Qty
Approved	