



solo per professionisti

Sirman Spa
 Viale dell'Industria 9/11
 35010 PIEVE DI CURTAROLO (PD), Italy
 Tel./Fax. +39 049 9698666 / +39 049 9698688
 email: info@sirman.com

Sirman Bowl Cutters , model C-tronic 4 :



- Sturdy body in die-cast and extruded aluminium.
- Motor and tank side-by-side, allowing the product to be isolated from the heat.
- S/S bowl with handles and heavy bottom.
- High efficiency ventilated motor for continuous operation
- Strong cutlery steel knives.
- Safety micro-switch on lid.
- Micro-switch on lever.
- Lid in transparent Tritan allowing excellent visibility during processing.
- Lid with opening to add ingredients during operation.
- Scraper spatula for cleaning the tank and lid during processing.
- Standard: spatula and sharpening stones.
- Variotronic: stabilised speed variator.

Options

- Hub with toothed blades.
- Hub with holed blades.
- Hub for pesto.
- Hub for dough mixes.



Scraper spatula for cleaning the tank and lid during processing



Variotronic: stabilised speed variator



Data sheet

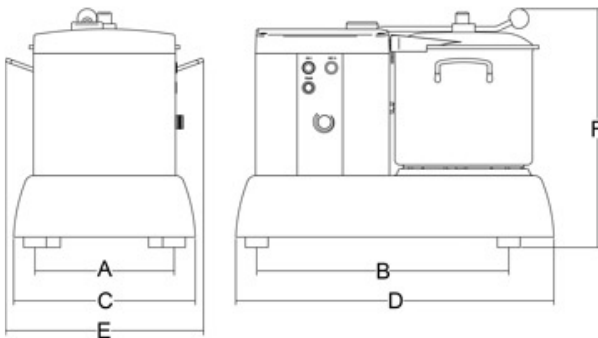

Technical data

Model	C-Tronic 4 VT
Power	watt 350 - Hp 0,5
Bowl capacity	lt 3,3
Bowl filling level	lt 1,5
Revolutions	rpm 600÷2.800
A	mm 185
B	mm 369
C	mm 251
D	mm 457
E	mm 296
F	mm 300
Net weight	kg 13
Shipping	mm 490x380x420
Gross weight	kg 15
HS-CODE	84386000