

INSTRUCTION, USER AND MAINTENANCE MANUAL

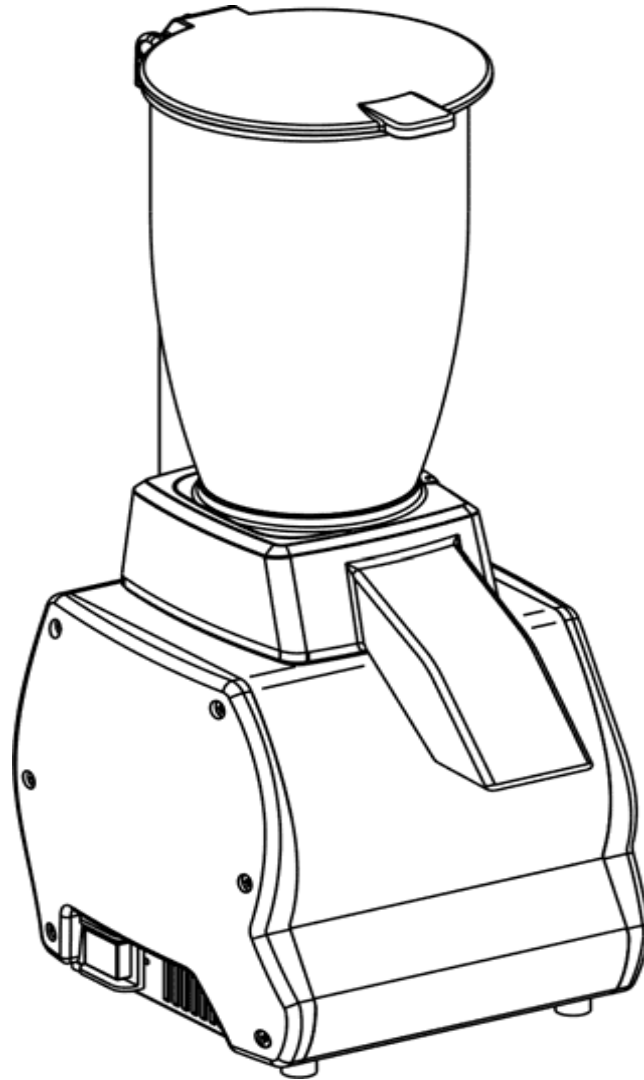

Ed. 04/2014

ICE BREAKER

FOREWORD

- This manual has been written to provide the **customer** with all the information on the machine and the regulations related to it, as well as the instructions for use and maintenance which allow you to use the device in the best way, keeping its efficiency intact over time.
- This manual should be given to the persons responsible for the use and periodic maintenance of the machine.

TABLE OF CONTENTS

CHAPTER 1 - INFORMATION ON THE MACHINE	pag. 4
1.1 - GENERAL PRECAUTIONS	
1.2 - SAFETY DEVICES INSTALLED ON THE MACHINE	
1.2.1 - Electrical and mechanical safety devices	
1.3 - DESCRIPTION OF THE MACHINE	
1.3.1 - General description	
1.3.2 - Design features	
1.3.3 - Composition of the machine	
CHAPTER 2 - TECHNICAL DATA	pag. 7
2.1 - OVERALL DIMENSIONS, WEIGHT, CHARACTERISTICS ...	
CHAPTER 3 - RECEIVING THE MACHINE	pag. 8
3.1 - SHIPMENT OF THE MACHINE	
3.2 - CHECKING THE PACKAGING UPON ARRIVAL	
3.3 - DISPOSAL OF THE PACKAGING	
CHAPTER 4 - INSTALLATION	pag. 9
4.1 - POSITIONING THE MACHINE	
4.2 - SINGLE-PHASE ELECTRICAL CONNECTION	
4.3 - WIRING DIAGRAM	
4.3.1 - Single-phase wiring diagram	
4.4 - CHECKING THE CORRECT OPERATION	
CHAPTER 5 - USING THE MACHINE	pag. 11
5.1 - CONTROLS	
5.2 - POSITION OF THE SAFETY MICRO ON THE ICE BREAKER	
5.3 - LOADING THE PRODUCT	
5.4 - ADJUSTING THE THICKNESS OF THE ICE	

CHAPTER 6 - CLEANING AND DRYING	pag. 13
6.1 - GENERAL INFORMATION	
6.2 - PROCEDURE TO FOLLOW TO CLEAN THE MACHINE	
CHAPTER 7 - MAINTENANCE	pag. 14
7.1 - GENERAL INFORMATION	
7.2 - POWER CORD	
7.3 - BLADE	
CHAPTER 8 - DISPOSAL	pag. 14
8.1 - PUTTING OUT OF SERVICE	
8.2 - WEEE Waste Electrical and Electronic Equipment	

CHAP. 1 - INFORMATION ON THE MACHINE

1.1 - GENERAL PRECAUTIONS

- The machine must be used only by trained personnel who must be fully aware of the safety regulations contained in this manual.
- In the case of a turnover of employees, make sure they are trained first.
- Before carrying out any cleaning or maintenance operations, disconnect the machine from the power supply.
- When carrying out cleaning or maintenance operations (and therefore the protections are removed), carefully assess the residual risks.
- During cleaning or maintenance keep your mind focused on the ongoing operations.
- Regularly check the condition of the power cord; a frayed or damaged cord is a serious electrical hazard.
- If the appliance does not work correctly or a malfunction is suspected, it is recommended that you do not use it and that you do not intervene directly to repair it, but contact the "Service Centre".
- Use the appliance only to break ice.
- Do not try to put your hands or other objects in the openings of the machine while it is on.
- Do not move the machine unless the switch is in "0" (off) position and the plug is disconnected from the power supply.
- The manufacturer is not liable in the following cases:
 - ⇒ the machine is tampered with by unauthorized personnel;
 - ⇒ some components have been replaced with other non-original ones;
 - ⇒ the instructions in this manual are not followed **carefully**; the surfaces of the machine are treated with unsuitable products.

1.2 - SAFETY DEVICES INSTALLED ON THE MACHINE

1.2.1 - Electrical and mechanical safety devices (see FIG. n°7)

As for the electrical and mechanical safety devices, the machine described in this manual complies with **Directives EEC 2006/42 and EEC 2006/95**.

The machine is equipped with the following safety devices:

- magnetic micro-switch on the lid;
- safety fuse in series with the power supply.

Although the unit is equipped with electrical and mechanical protective devices (both during operation and during cleaning and maintenance), there are still **RESIDUAL RISKS** that cannot be completely eliminated, mentioned in this manual as **WARNINGS**. They concern the danger of cuts resulting from contact with the blade while cleaning.

1.3 - DESCRIPTION OF THE MACHINE

1.3.1 - General description

The ice breaker has been designed and made by our company with the purpose of breaking normal sized ice cubes max. 25x30 mm, produced by the manufacturer (no freezer), it also guarantees:

- maximum safety during use, cleaning and maintenance;
- maximum hygiene, obtained thanks to a meticulous selection of the materials that come into contact with food, and to the elimination of edges in the parts of the machine that come into contact with the product, so as to allow thorough and easy cleaning as well as simple disassembly;
- sturdiness and stability of all the components;
- easy to handle.

1.3.2 - Design features

- Anodized aluminium body and column.
- AISI 304 steel cup.
- Chute, lid and guillotine made of ABS plastic.
- ABS plastic sides.
- AISI 304 steel blade and ice breaker plate.
- Tray (optional) made of PS thermoformed polystyrene for food-contact.
- Rubber feet and stainless steel screws.

1.3.3 - Composition of the machine FIG. n°1 -
General view of the machine

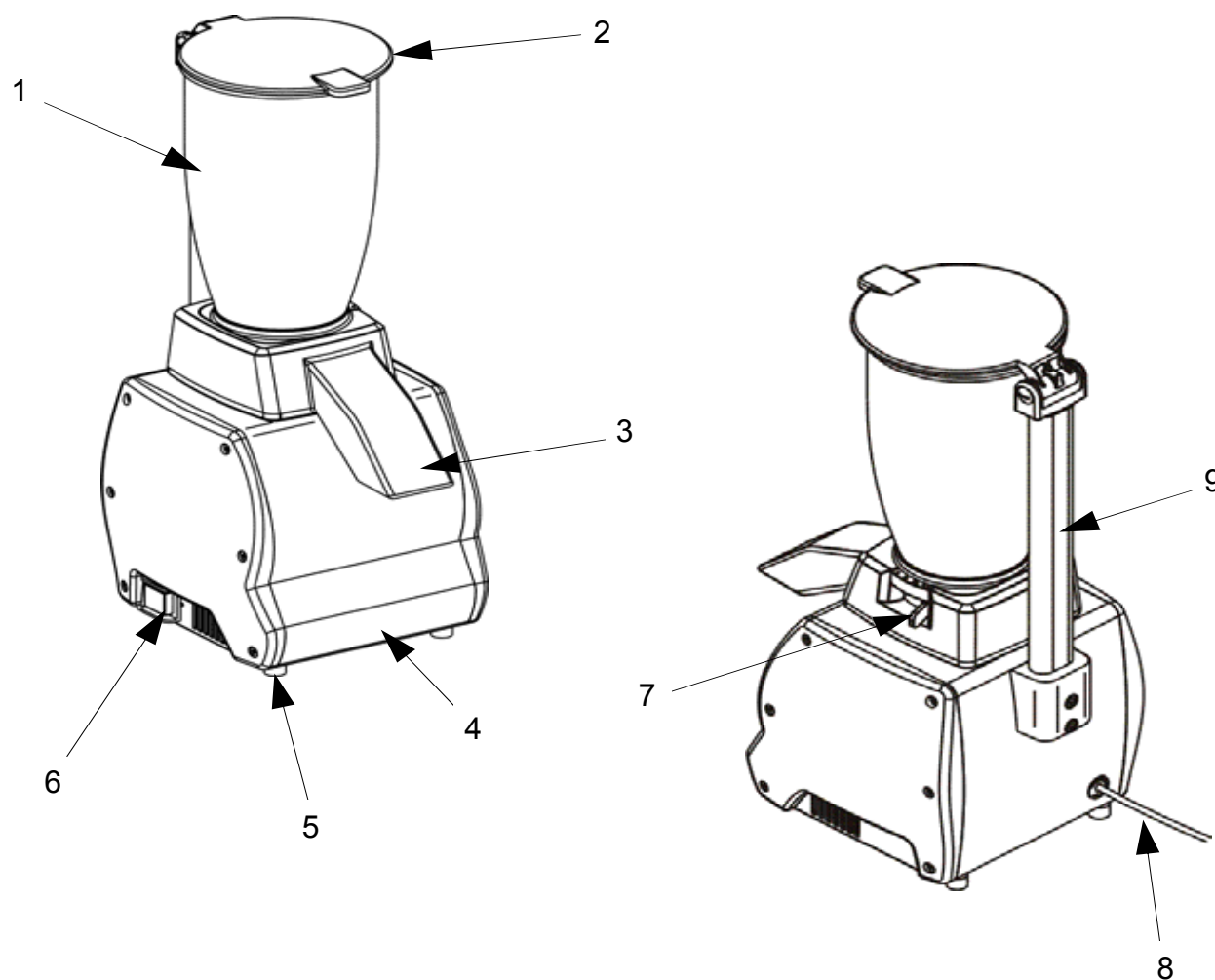

LEGEND:

- 1. Cup
- 2. Lid
- 3. Chute
- 4. Body of the machine
- 5. Foot
- 6. Switch
- 7. Thickness adjusting guillotine
- 8. Power cord
- 9. Lid supporting column

CHAP. 2 - TECHNICAL DATA

2.1 - OVERALL DIMENSIONS, WEIGHT, CHARACTERISTICS... FIG. n°2 - Overall dimensions

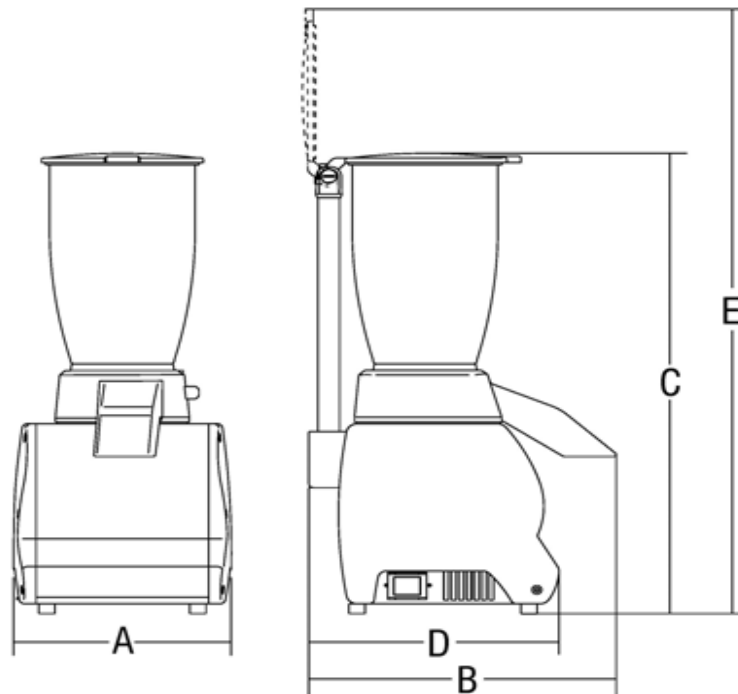

TAB. n°1 - OVERALL DIMENSIONS AND TECHNICAL CHARACTERISTICS

Model		Ice breaker
A	<i>mm</i>	205
B	<i>mm</i>	285
C	<i>mm</i>	491
D	<i>mm</i>	235
E	<i>mm</i>	650
Power	<i>watt</i>	150
Power supply		230V/50Hz
Rotations per minute	<i>r.p.m.</i>	800
Net weight	<i>kg</i>	5.2
Degree of noise	<i>dB</i>	≤ 60

WARNING: The electrical characteristics of the machine are indicated on a plate on the back of the machine; before connecting, see **4.2 electrical connection**.

CHAP. 3 - RECEIVING THE MACHINE

3.1 - SHIPMENT OF THE MACHINE (see FIG. n°3)

The machine leaves our warehouse carefully packed; the packaging consists of:

- a) external box made of sturdy cardboard possibly including separators
- b) the machine
- c) this manual
- d) EC certificate of conformity
- e) ice tray (optional)

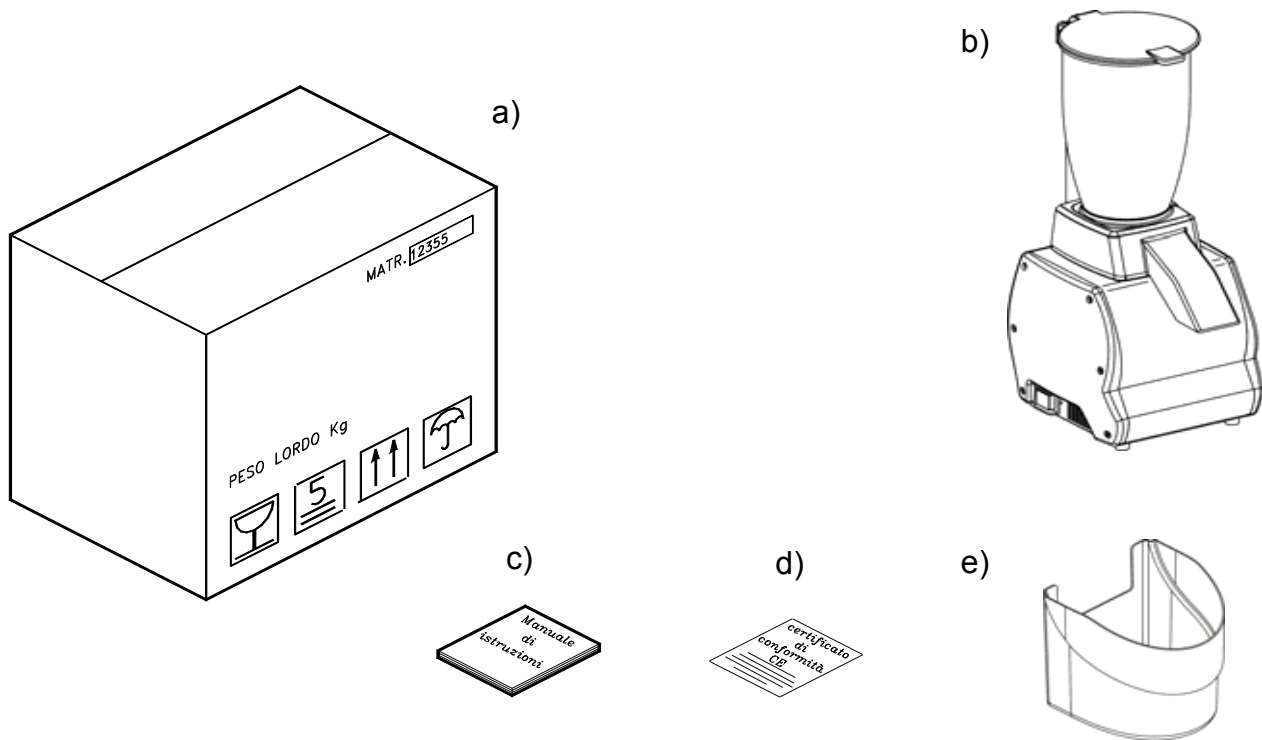

FIG. n°3 - Description of the package

3.2 - CHECKING THE PACKAGING UPON ARRIVAL

When you receive the package, if it has no external damage, proceed to open it, checking that all the material is inside (see FIG. n°3). Instead, if upon delivery the package shows signs of mistreatment, falls or impact, it is necessary to point out the damage to the courier, and within 3 days from the delivery date indicated on the documents, write a detailed report on the damage suffered by the machine. **Do not turn the package upside-down!!** When being transported, make sure that it is held at the four corners (keeping it parallel to the floor).

3.3 - DISPOSAL OF THE PACKAGING

The components of the packaging (cardboard, plastic straps) are classified as municipal solid waste; for this reason they can be disposed of without difficulty. If the machine is installed in countries where there are special rules, the packaging must be disposed of in accordance with the regulations in force.

CHAP. 4 - INSTALLATION

4.1 - POSITIONING THE MACHINE

The surface on which the machine is to be placed must take into account the support size indicated in Tab. 1, and therefore be big enough; it must be perfectly level, dry, smooth, sturdy and stable. In addition, the machine must be placed in a room with max. 75% humidity, non-saline and a temperature between +5°C and +35°C; in any case, in environments that do not involve dysfunctions of the same.

4.2 - SINGLE-PHASE ELECTRICAL CONNECTION

The machine is equipped with a power cord with a cross section of 3x0.75 mm²; length 1.5 m and a "SHUKO" plug. Connect the machine 230 Volt 50 Hz, interposing a 10A, $\Delta I = 0.03A$ differential—magnetothermic switch. Make sure that the earthing system works correctly. Also check that the information on the technical plate (FIG.n°4) corresponds to the information given on the delivery and guidance documents.

Mod.	_____
Matr.	_____ Watt.
_____ H.p.	_____ A. _____ Hz.
○ _____	~ Volts. _____ Kg. ○
Anno	_____

FIG. n°4 - Technical plate

4.3 - WIRING DIAGRAM

4.3.1 - Single-phase wiring diagram

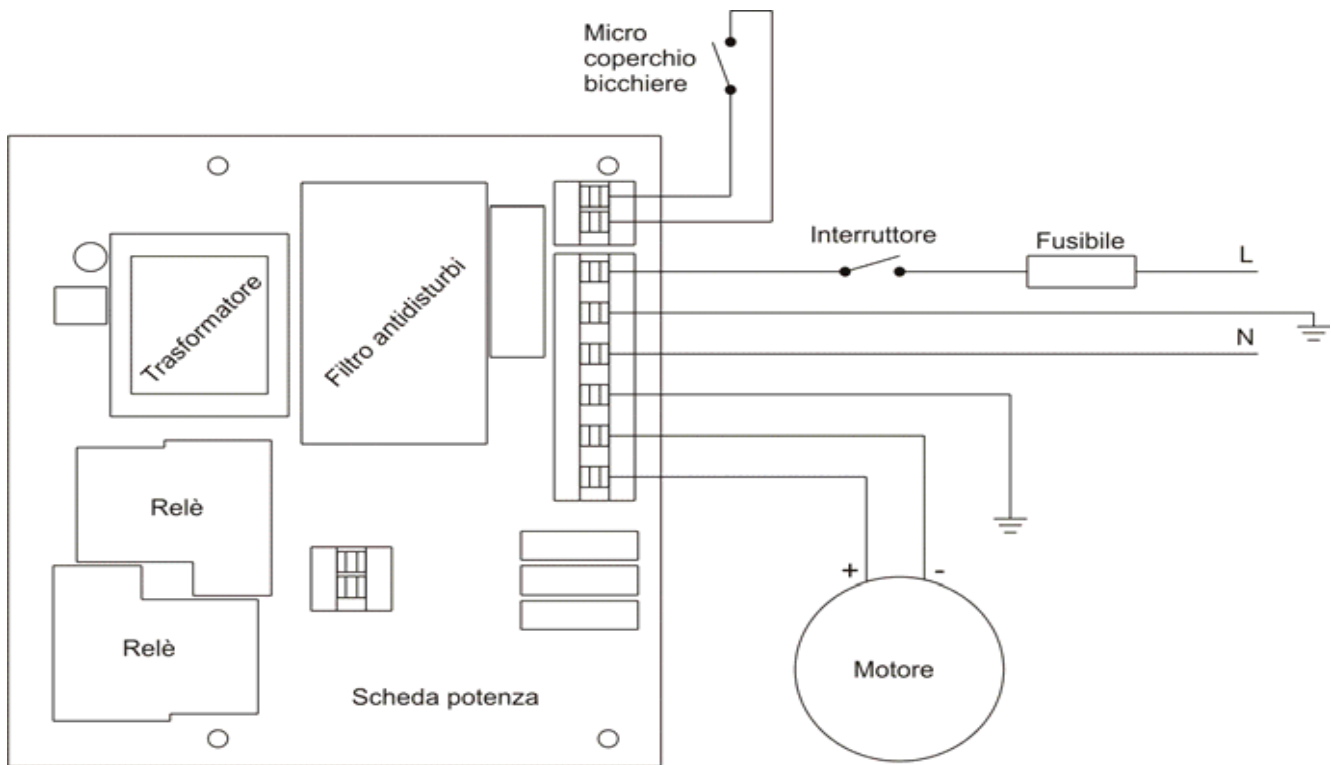

FIG. n°5 - Wiring diagram

4.4 - CHECKING THE CORRECT OPERATION N.B.

N.B. Before testing, make sure that (see FIG. n°7):

- a) the lid is low enough to react with the magnetic micro-switch (ref. a);
- b) after which test the operation using the following procedure:

1. operate the switch by moving to the "I" position;
2. check if the appliance stops working when lifted.
3. at the end, bring the switch to "0" off position.

CHAP. 5 - USING THE MACHINE

5.1 - CONTROLS

The controls are placed on the body of the machine as shown below.

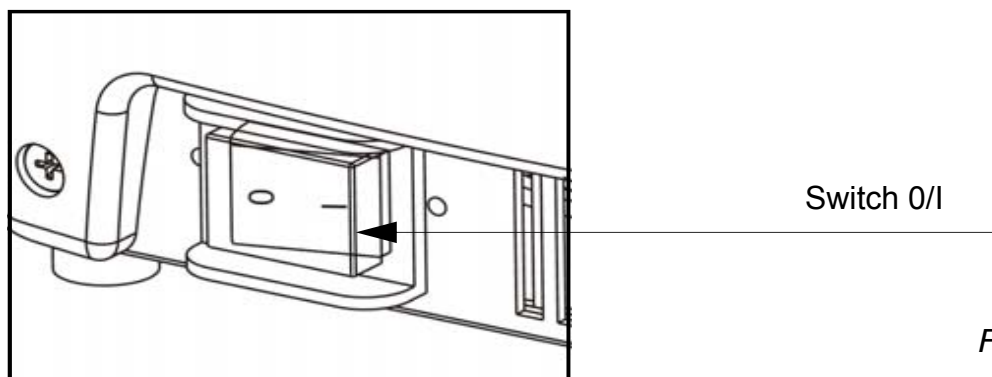

FIG. n°6 - Controls

5.2 - POSITION OF THE SAFETY MICRO ON THE ICE BREAKER

- a) Magnetic micro-switch: blocks the operation of the ice breaker when the lid of the cup is lifted.

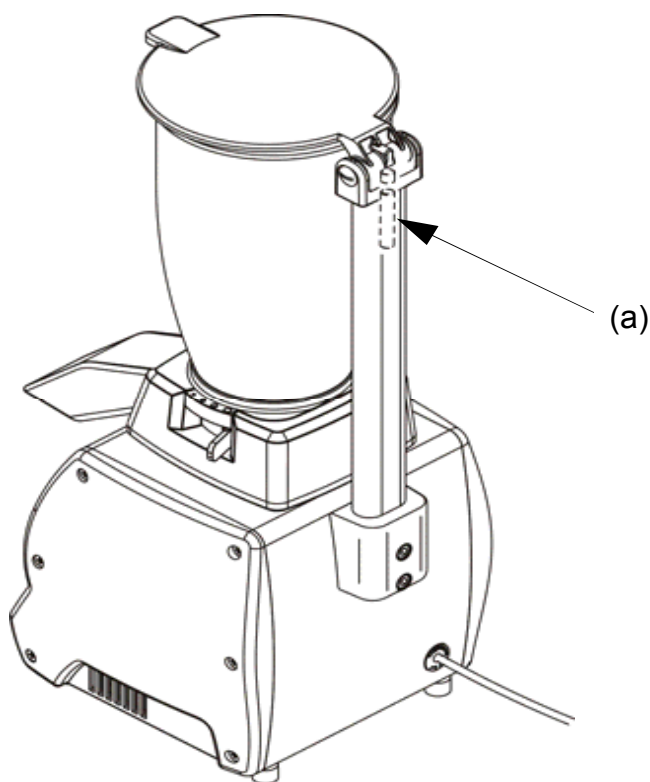

FIG. n°7 - Position of safety micro

5.3 - LOADING THE PRODUCT

WARNING!

The ice to be broken must be loaded into the feed chute only when the motor is off. Use ONLY hollow ice cubes 25x30 mm at -3°C produced by the manufacturer NO FREEZER.

N.B.: the amount of ice to be inserted must not go beyond the edge of the cup, otherwise the machine will not turn on.

The procedure is as follows:

1. lift the lid of the cup;
2. insert the ice, paying attention to the amount: you must be able to close the lid;
3. turn the machine on by pressing the "I" button;
4. assume a correct position in order to avoid accidents (see *FIG. n°9*): your body must be perpendicular to the work surface. **In any case, do not lean against the machine and avoid assuming positions that involve direct contact with the machine, but use the lid.**
5. at the end of the process stop the machine by pressing the "0" button;
6. avoid operating the ice breaker when empty;
7. make sure that when you have finished using the machine you immediately place a container under the chute, as the ice remaining inside will melt and drip onto the surface, which may cause risks.
8. **Do not move the machine if the switch is not on "0" (off) position and the plug is not disconnected from the power supply.**
9. **If the broken ice is not of the desired consistency, you can use the guillotine to adjust the thickness of the ice.**
10. Do not leave ice inside the cup for a long time: it may homogenize and prevent the rotation of the blade, causing serious damage to the machine.

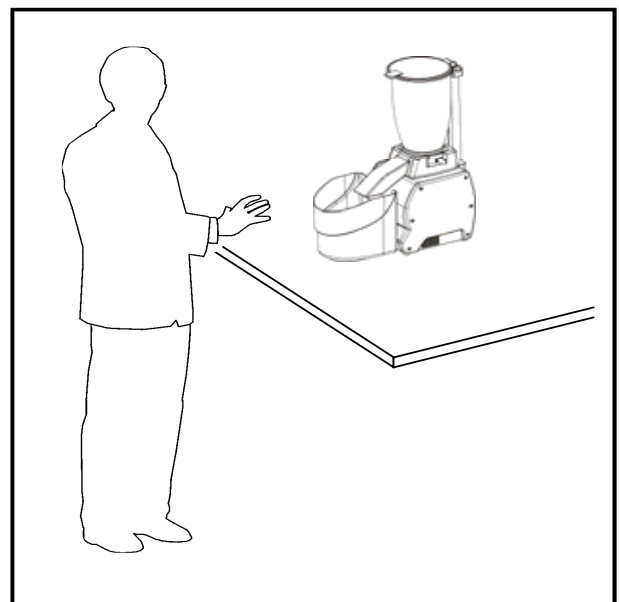

FIG. n°8 - Correct position

5.4 - ADJUSTING THE THICKNESS OF THE ICE

The procedure to adjust the thickness of the ice is the following:

- 1) bring the switch to "0".
- 2) move the guillotine (*Fig. n.1 - ref. 7*) backward or forward to adjust the thickness.
- 3) once you have set the desired thickness, you can start to use the ice breaker.

CHAP. 6 - CLEANING AND DRYING

6.1 - GENERAL INFORMATION

- The machine does not require special cleaning.
- The machine must be dried at the end of each working cycle.
- All parts of the machine must be cleaned using only a sponge or an absorbent cloth.
- The machine must not be cleaned using high-pressure cleaners or water jets. Do not use utensils, brushes or other devices that may damage the surface of the machine.

"WARNING!"

Before performing any cleaning operations it is necessary to:

- a) bring the switch to "0".
- b) disconnect the plug from the socket to isolate the machine completely from the rest of the system.

6.2 - PROCEDURE TO FOLLOW TO CLEAN THE MACHINE

N.B. Do not wash any part of the ice breaker in the dishwasher.

The body of the machine and the chute can be cleaned with mild detergent and a damp cloth rinsed frequently with warm water.

WARNING: once the ice breaker has been cleaned in all its parts, dry well and close the lid of the cup.

CHAP. 7 - MAINTENANCE

7.1 - GENERAL INFORMATION

Before performing any maintenance it is necessary to:

disconnect the plug from the socket to isolate the machine completely from the rest of the system.

7.2 - POWER CORD

Periodically check the state of wear of the cord and if necessary call the "SERVICE CENTRE" for it to be replaced.

7.3 - BLADE

Periodically check the condition of the blade, if a replacement is needed contact the "SERVICE CENTRE".

CHAP. 8 - DISPOSAL

8.1 - PUTTING THE MACHINE OUT OF SERVICE

If for some reason you decide to put the machine out of service, make sure that it cannot be used by anybody: **remove the blade, disconnect and cut the electrical connections.**

8.2 - WEEE Waste Electrical and Electronic Equipment



According to article 13 of the Legislative Decree of 25th July 2005, n.151 "Implementation of Directives 2002/95/EC, 2002/96/EC and 2003/108/EC, concerning the reduction of hazardous substances in electrical and electronic equipment, and disposal of waste".

The symbol of the crossed-out dustbin on the appliance or on its packaging indicates that, at the end of its life, the product must be separated from other waste.

The recycling of this appliance at the end of its life is organized and managed by the manufacturer. The user who wishes to dispose of this appliance will therefore have to contact the manufacturer and follow the system that the latter has adopted for the separate collection of equipment that has reached the end of its life.

The separate collection for the subsequent recycling, treatment and environmentally compatible disposal of the equipment contributes to avoiding possible negative effects on the environment and on human health and promotes the reuse and/or recycling of the materials of which the equipment is composed.

Improper disposal of the product by the holder involves the application of the administrative sanctions provided by law.

***SERVICE CENTRE
AUTHORIZED DEALER***

4.3 - WIRING DIAGRAM

4.3.1 - Single-phase wiring diagram

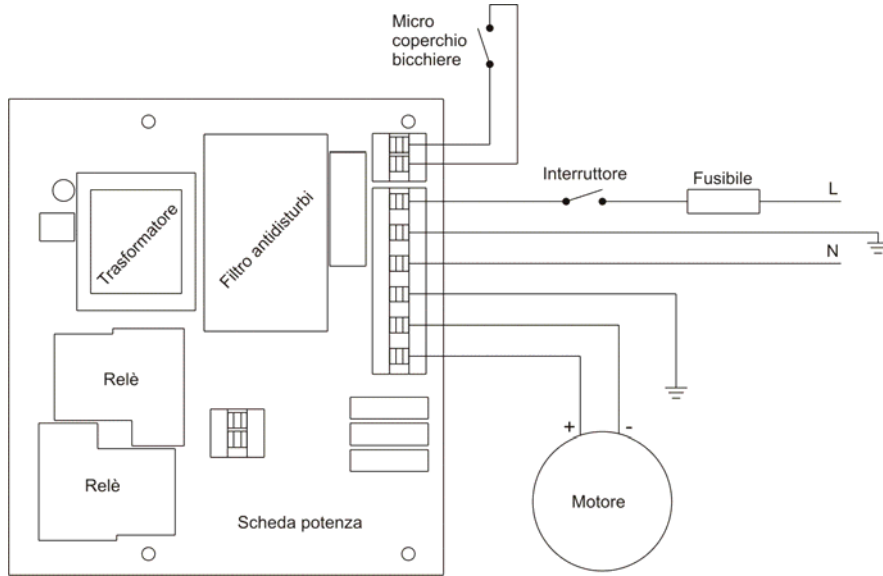

FIG. n°5 - Wiring diagram

4.4 - CHECKING THE CORRECT OPERATION

N.B. Before testing, make sure that (see FIG. n°7):

- a) the lid is low enough to react with the magnetic micro-switch (ref. a);
- b) after which test the operation using the following procedure:

1. operate the switch by moving to the "1" position;
2. check if the appliance stops working when lifted.
3. at the end, bring the switch to "0" off position.

CHAP. 2 - TECHNICAL DATA

2.1 - OVERALL DIMENSIONS, WEIGHT, CHARACTERISTICS...

FIG. n°2 - Overall dimensions

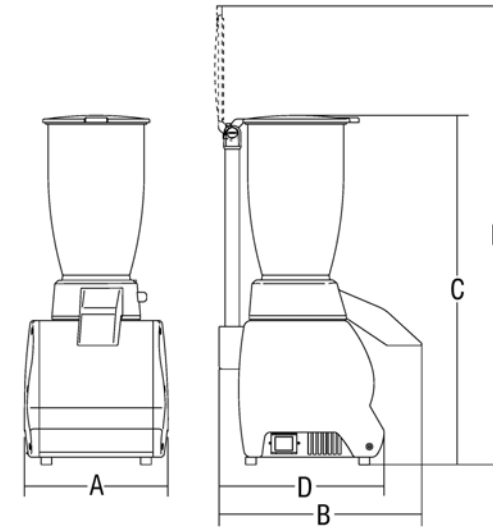

TAB. n°1 - OVERALL DIMENSIONS AND TECHNICAL CHARACTERISTICS

Model		Ice breaker
A	mm	205
B	mm	285
C	mm	491
D	mm	235
E	mm	650
Power	watt	150
Power supply		230V/50Hz
Rotations per minute	r.p.m.	800
Net weight	kg	5.2
Degree of noise	dB	≤ 60

WARNING: The electrical characteristics of the machine are indicated on a plate on the back of the machine; before connecting, see **4.2 electrical connection**.

CHAP. 3 - RECEIVING THE MACHINE

3.1 - SHIPMENT OF THE MACHINE (see FIG. n°3)

The machine leaves our warehouse carefully packed; the packaging consists of:

- external box made of sturdy cardboard possibly including separators
- the machine
- this manual
- EC** certificate of conformity
- ice tray (optional)

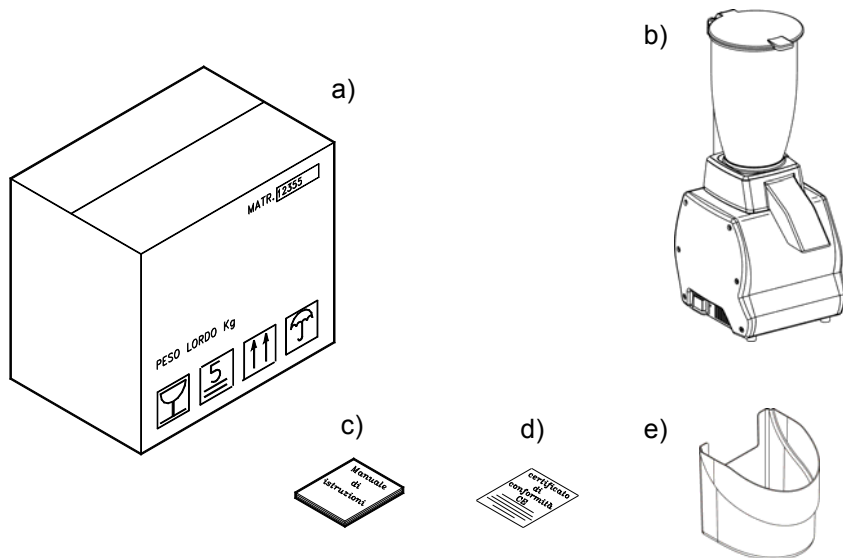

FIG. n°3 - Description of the package

3.2 - CHECKING THE PACKAGING UPON ARRIVAL

When you receive the package, if it has no external damage, proceed to open it, checking that all the material is inside (see FIG. n°3). Instead, if upon delivery the package shows signs of mistreatment, falls or impact, it is necessary to point out the damage to the courier, and within 3 days from the delivery date indicated on the documents, write a detailed report on the damage suffered by the machine. **Do not turn the package upside-down!!** When being transported, make sure that it is held at the four corners (keeping it parallel to the floor).

3.3 - DISPOSAL OF THE PACKAGING

The components of the packaging (cardboard, plastic straps) are classified as municipal solid waste; for this reason they can be disposed of without difficulty.

If the machine is installed in countries where there are special rules, the packaging must be disposed of in accordance with the regulations in force.

CHAP. 4 - INSTALLATION

4.1 - POSITIONING THE MACHINE

The surface on which the machine is to be placed must take into account the support size indicated in Tab. 1, and therefore be big enough; it must be perfectly level, dry, smooth, sturdy and stable.

In addition, the machine must be placed in a room with max. 75% humidity, non-saline and a temperature between +5°C and +35°C; in any case, in environments that do not involve dysfunctions of the same.

4.2 - SINGLE-PHASE ELECTRICAL CONNECTION

The machine is equipped with a power cord with a cross section of 3x0.75 mm²; length 1.5 m and a "SHUKO" plug.

Connect the machine 230 Volt 50 Hz, interposing a 10A, $\Delta I = 0.03A$ differential—magnetothermic switch. Make sure that the earthing system works correctly.

Also check that the information on the technical plate (FIG.n°4) corresponds to the information given on the delivery and guidance documents.

Mod.	_____	Watt.	_____
Matr.	_____	Hz.	_____
	H.p. _____	A.	_____
○	_____	Volts.	_____
Anno	_____	Kg.	○

FIG. n°4 - Technical plate