

Tray thermo-sealer CE professional

20



Ed. 03/2016

Instruction Manual, for Use and Maintenance

FOREWORD

*This manual has been drafted in order to provide the **Customer** with all the information on the machine and on the relating safety regulations, as well as all use and maintenance instructions, allowing to use the means in the best way possible, preserving efficiency intact in the course of time.*

This manual must be kept and preserved intact until machine disposal.

This manual is delivered to the staff assigned to use the machine and perform the routine maintenance.

INDEX OF CHAPTERS

CHAP. 1 - MANUAL	page 5
1.1 PURPOSE	
1.2 USERS	
1.3 - USE AND PRESERVATION	
1.4 - MANAGEMENT AND RESPONSIBILITY	
CHAP. 2 – INFORMATION ON THE MACHINE	page 6
2.1 GENERAL PRECAUTIONS	
CHAP. 3 – TECHNICAL SPECIFICATIONS	page 7
3.1 - SAFETY DEVICES INSTALLED ON THE MACHINE	
3.1.1 - Safety electrical devices	
3.2 - WARNING SIGNS	
CHAP. 4 – ABOUT THE MACHINE	page 9
4.1 DESIGN FEATURES	
4.2 - DESCRIPTION OF THE MACHINE	
4.3 - COMPOSITION OF THE MACHINE	
CHAP. 5 – TRASPORT PACKAGING AND UNPACKAGING	page 10
5.1 - PACKING	
5.2 - CHECK OF THE PACKAGING UPON RECEIPT	
5.3 - UNPACKAGING	
CHAP. 6 – TECHNICAL DATA	page 12
6.1 SIZE REQUIREMENT, WEIGHT AND FEATURES	
CHAP. 7 – INSTALLATION	page 13
7.1 POSITIONING	
7.2 - ELECTRICAL CONNECTION	
7.2.1 - Monophase sealer	
7.3 - WIRING DIAGRAM MONOPHASE 230V	
CHAP. 8 – USE OF THE MACHINE	page 14
8.1 - POSITIONING OF THE FILM	
8.1.2 - Positioning of the mould	
8.2 PRELIMINARY CHECKS	

CHAP. 9 – USE OF THE MACHINE

page 15

9.1 - STARTING THE MACHINE

9.1.2 - Setting the use parameters

9.1.3 - Sealing – procedure

CHAP. 10 – ISSUES AND SOLUTIONS

page 18

10.1. - POSSIBLE ERRORS

CHAP. 11 – ROUTINE CLEANING

page 18

11.1 - GENERALS

11.2 - CLEANING OF THE MACHINE

CHAP. 12 - DISMANTLING

page 19

12.1 DECOMMISSIONING

12.2 - WEEE WASTE ELECTRICAL AND ELECTRONIC
EQUIPMENT LEVELS

CHAP. 1 – THE MANUAL

1.1 - PURPOSE

- The purpose of the Manual consists in providing the instructions as well as the information, to scrupulously follow for a correct use of the machine and for the protection and safety of the operator, who must interact with it. The Manual describes the use of the machine, as provided by the project as well as the technical features of the machine, provides for instructions on how to move it, for an appropriate and safe installation, assembly, adjustment and use; it provides for information relating to the maintenance interventions as well as the information required to order the spare parts. The Manual clearly shows the uses, which are not allowed, of the machine, highlighting the residual risks, with indication of the safety prescriptions to control them.

1.2 - USERS

The Manual is intended to be used by professional and suitably trained personnel and, specifically by:

- Machine operators
- Maintenance engineers
- Electrical maintainers

1.3 - USE AND PRESERVATION

- Each machine model is sold with its own Instruction Manual. The manual forms an integral part of the machine and it must be preserved in good condition until the machine is dismantled.
- **THE MANUAL MUST BE PRESERVED IN A SAFE, DRY PLACE, PROTECTED AGAINST DIRECT SUNLIGHT AND IT MUST ALWAYS BE AVAILABLE FOR CONSULTATION, IN PROXIMITY TO THE MACHINE.**
- In case of transfer of the machine, the Manual must be conveyed to the new owner.

1.4 - MANAGEMENT AND RESPONSIBILITY

This Manual represents the current status of the machine's technique and can-

not be considered inappropriate in case of updates of the model, occurred after the issue of the same Manual. The Manufacturer reserves the right to update products and manuals, with no obligation to update manuals and previous production. The Manufacturer shall hold the rights of intellectual property of this Manual and it shall forbid its integral and partial disclosure, in any form (print, copies, microfilms, or other means), as well as the processing, reproduction or dissemination by electronic systems, towards private individuals or corporations without its approval. The User is responsible for the management of the Manual for the entire machine life and will provide for its destruction only upon disposal of the same machine. Any requests for further copies of this document must be regularised with a purchase order sent to the Manufacturer.

CHAP. 2 – INFORMATION ON THE MACHINE

2.1 – GENERAL PRECAUTIONS

Although they may seem predictable, the general precautions are essential for the installations, the use and the maintenance as well as for any inconveniences with relating solutions.

- The machine has been designed for the sealing of trays for food use, containing packageable food.
- It is strictly forbidden to use flammable and/or harmful material.
- The Manufacturer shall be relieved from all responsibilities in the following cases:
 - **the machine is used by unauthorized personnel;**
 - **components are replaced with non-original ones;**
 - **the instructions, contained in this manual, are not carefully followed;**
 - **the surfaces of the machine are cleaned with inappropriate products.**
- Take good care of this manual for future information or consultations (Fig. n°1).

- The machine must be used only by trained personnel, who must perfectly know the safety regulations, contained in this manual. In case of personnel turnover, training must be provided beforehand.

- Do not allow the machine to be used by children or incompetent individuals, and, in any case, by untrained individuals (Fig. n°2).

- During intervention for routine maintenance or machine cleaning, carefully assess the residual risks. During service or cleaning, keep your mind focused on the ongoing operations.

- For machine cleaning, do not use corrosive or flammable substances (Fig. n°3); **use only neutral products (pH 7).**

- For cleaning, carefully follow the instructions of the chapter: "Routine cleaning".
- Do not wash the machine with water jets, with rough or abrasive means,

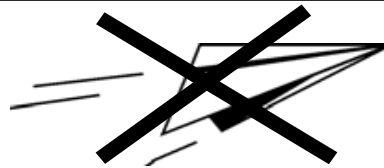

Fig. n°1



Fig. n°2



Fig. n°3

which may ruin the surfaces, do not dip it in water or in other liquids.

- Do not leave the machine exposed to harmful agents: sun, rain, sprays, humidity, ice (*Fig. n°4*).
- Do not pull the machine or the power supply cable (*Fig.n°5*), to disconnect the plug from the power source.
- Regularly check the status of the power supply cable; a used or, in any case, a non-intact cable represents a serious electrical danger.

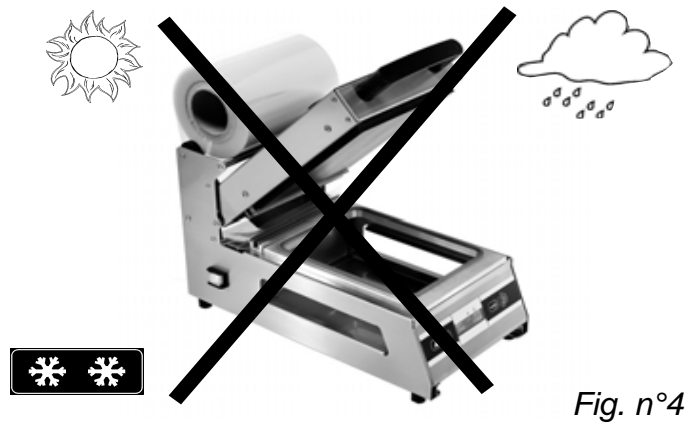

Fig. n°4

- Shall the machine remain unused for long periods, before using it, an “Assistance Centre” must check it. Shall the machine give the impression of or show a malfunction, it is recommended to shut it off and to not use, to not intervene directly for repairs and to contact the “Assistance Centre”, shown on the back of this manual.

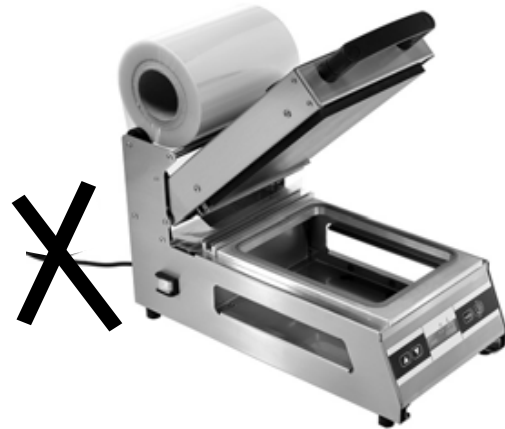

Fig. n°5

- Do not keep the machine uselessly on. Disconnect the plug from the power source when the machine is not being used.
- **CAUTION! NEVER introduce your hands inside the hot machine, the welding plate may cause serious burns.**

CHAP. 3 – TECHNICAL SPECIFICATIONS

3.1 – SAFETY DEVICES INSTALLED ON THE MACHINE

3.1.1 – Electrical safety devices

As for the electrical safety devices, the machine described in this manual complies with the:

- low voltage directive **CEE 2006/95**;
- electromagnetic compatibility directive **2004/108**.

Despite the **CE** professional tray sealer is provided with the regulation measures for electrical protections (both during the operation mode and during the cleaning and maintenance stage), yet, there are some **RESIDUAL RISKS** which cannot be completely removed, recalled in this manual under the entry **ATTENTION**. They relate to the danger of burns, deriving from the contact with hot parts of the machine and cut danger deriving from the contact with the blade of the slitter.

3.2 – WARNING SIGNS

Danger label, showing the achievement of high temperatures on the welding plate.
Avoid any type of contact.



Fig. n°6

Label, showing the cut danger or other injuries of the same type in the slitter.

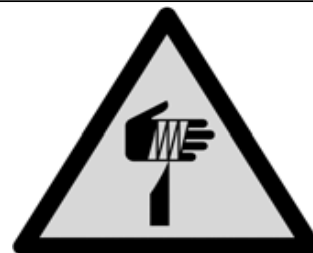

Fig. n°7

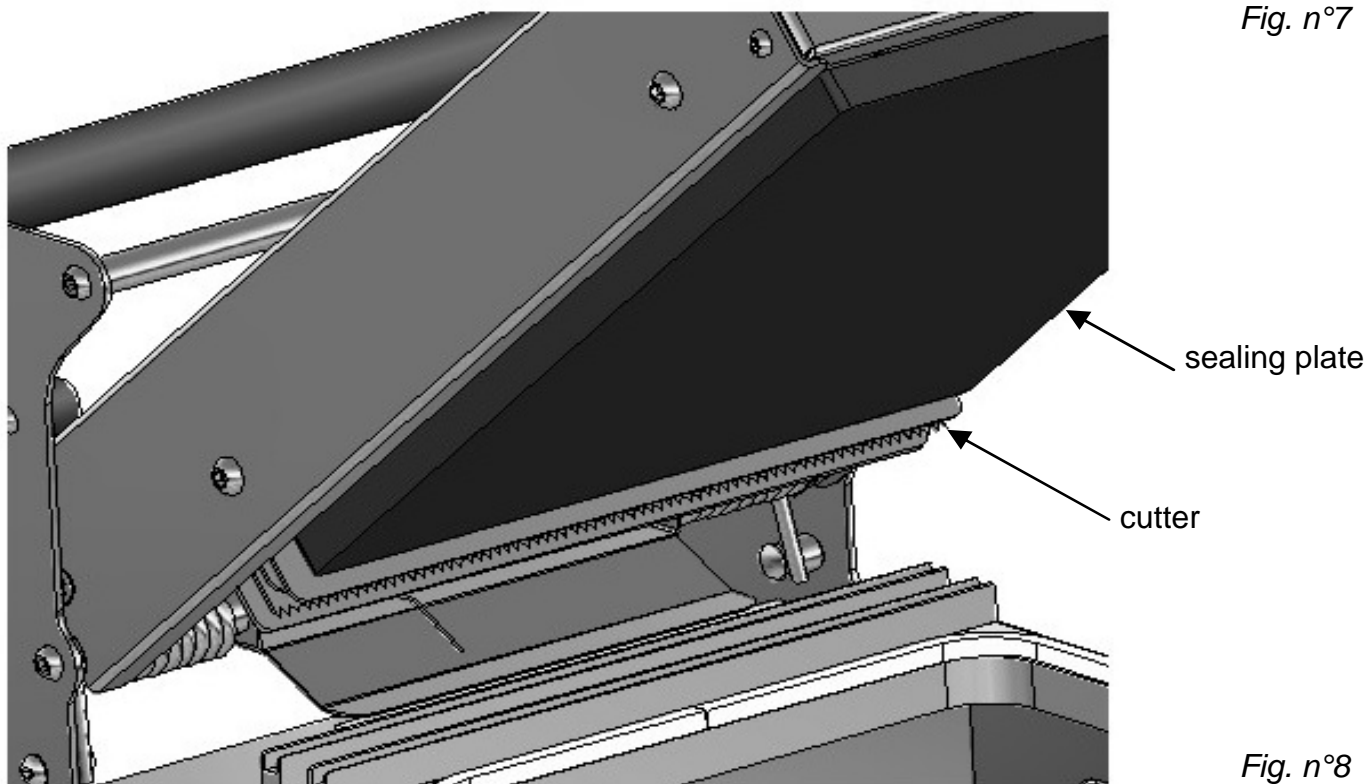

Fig. n°8



WARNING!

- Before performing any cleaning or maintenance operation, disconnect the plug of the machine from the electrical power supply network.

CHAP. 4 – ABOUT THE MACHINE

4.1 – CONSTRUCTION FEATURES

The machine mainly consists in a stainless steel structure AISI 304, whereas the welding plate consists in Teflon-coated aluminium.

4.2 – DESCRIPTION OF THE MACHINE

Tray sealers have been designed and implemented by the same firm with the exact purpose of sealing food inside trays for food use and assure:

- maximum safety as for use, cleaning and maintenance;
- maximum hygiene, achieved owing to a detailed selection of the materials, which enter into contact with the food;
- firmness and stability of all the components.

4.3 – MACHINE COMPOSITION

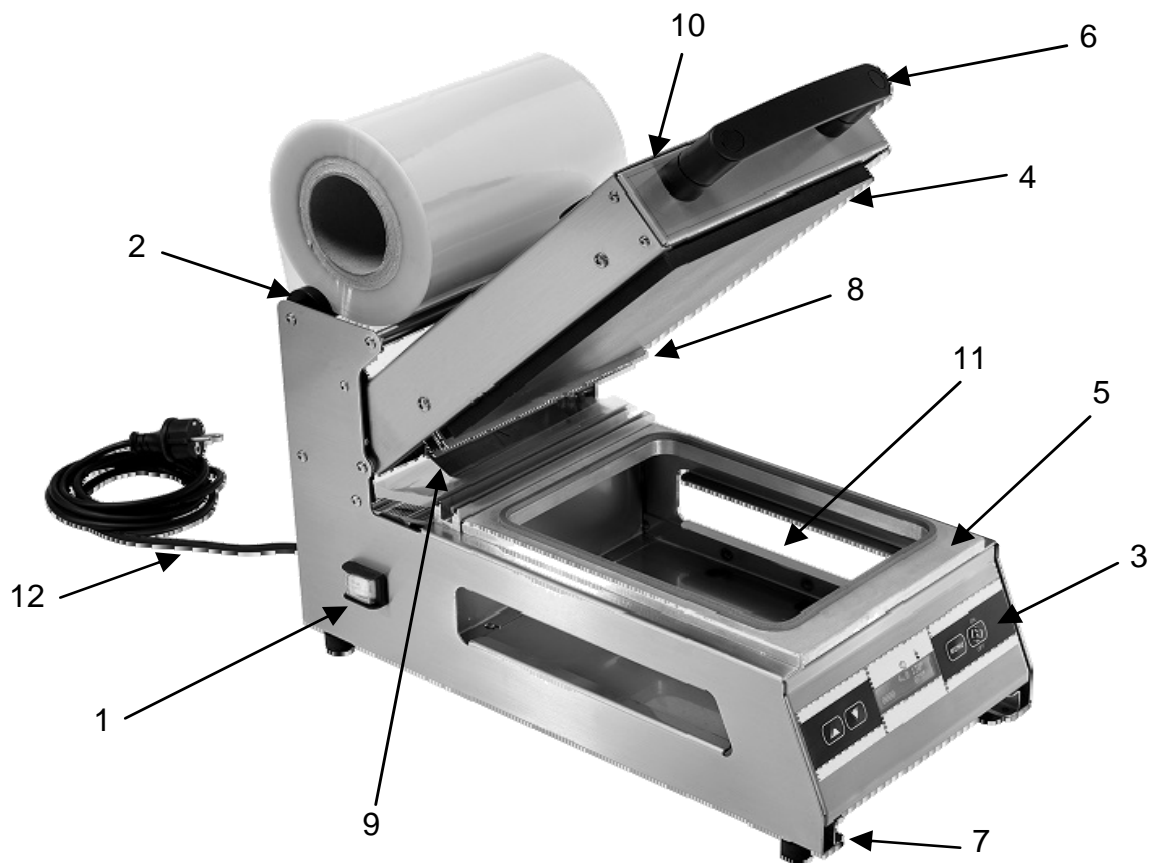

Fig. n°9

Legend

- | | |
|-----------------------------|-----------------------|
| 1 Main ON/OFF switch | 7 Slot for mould |
| 2 Film reel support rollers | 8 Cutter |
| 3 Control board | 9 Film-pressing sheet |
| 4 Sealing plate | 10 Sealing head |
| 5 Tray mould | 11 Tray chamber |
| 6 Handle | 12 Power cord |

CHAP. 5 – TRASPORT PACKAGING AND UNPACKAGING

5.1 – PACKAGING

The packaging, in which the machine is shipped, is made up of (Fig. n°10): cardboard box, protection nylon material and cardboard inserts. Therefore, they shall be disposed separately and in compliance with the regulations in force in the installation country.

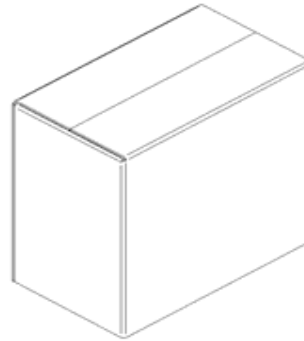

Fig. n°10

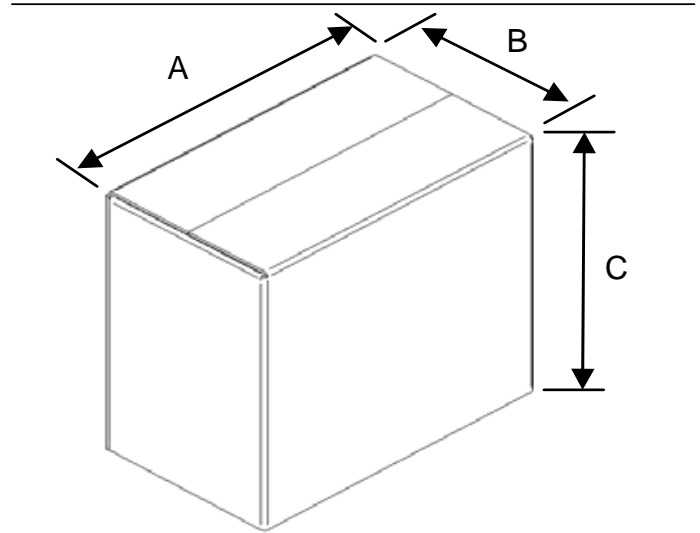

Fig. n°11

Dimensions AxBxC (mm)	Gross weight (Kg)
620x380x400	22



Do not leave the packaging exposed to humidity and rain (Fig. n°12).

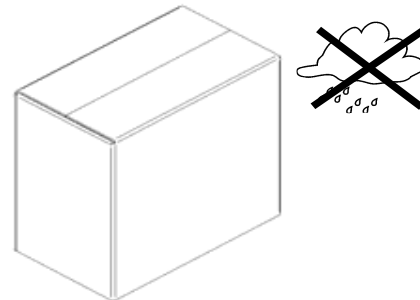

Fig. n°12



Heavy packaging. Do not lift manually without the support of minimum two people (Fig. n°13).

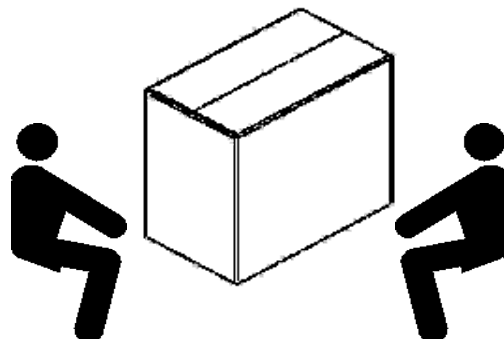

Fig. n°13



WARNING!

Do not stack up more than two packagings. (Fig. n°14).

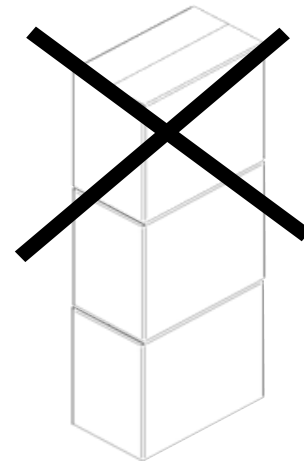

Fig. n°14

5.2 – CHECK OF THE PACKAGING UPON RECEIPT

Upon received of the package, shall it not feature external damages, proceed with its opening and check that all the material is present inside. On the contrary, if upon delivery the parcel features signs of mistreatment (Fig. n°15), collision or fall, it is necessary to inform the courier about the damages, and within three days from the delivery date, shown on the documents, draw up an accurate report on any damages undergone by the machine.

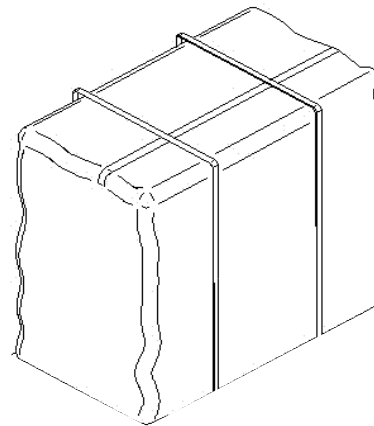

Fig. n°15

Do not overturn the packaging!! Upon transportation, make sure that it is grabbed firmly from the 4 corners (thus keeping it parallel to the floor).



WARNING!

All the operations must be carried out by the specialized technical personnel (Fig. n°16).



Fig. n°16

5.3 – UNPACKAGING

Open the box (Fig. n°17), remove the protection nylon material from the machine and lift it up carefully.

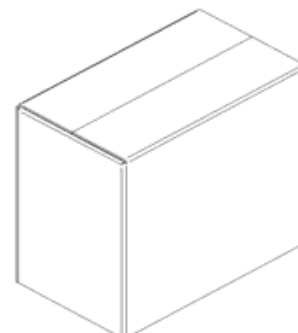

Fig. n°17

CHAP. 6 - TECHNICAL DATA

6.1 – SIZE REQUIREMENT, WEIGHT, FEATURES ...

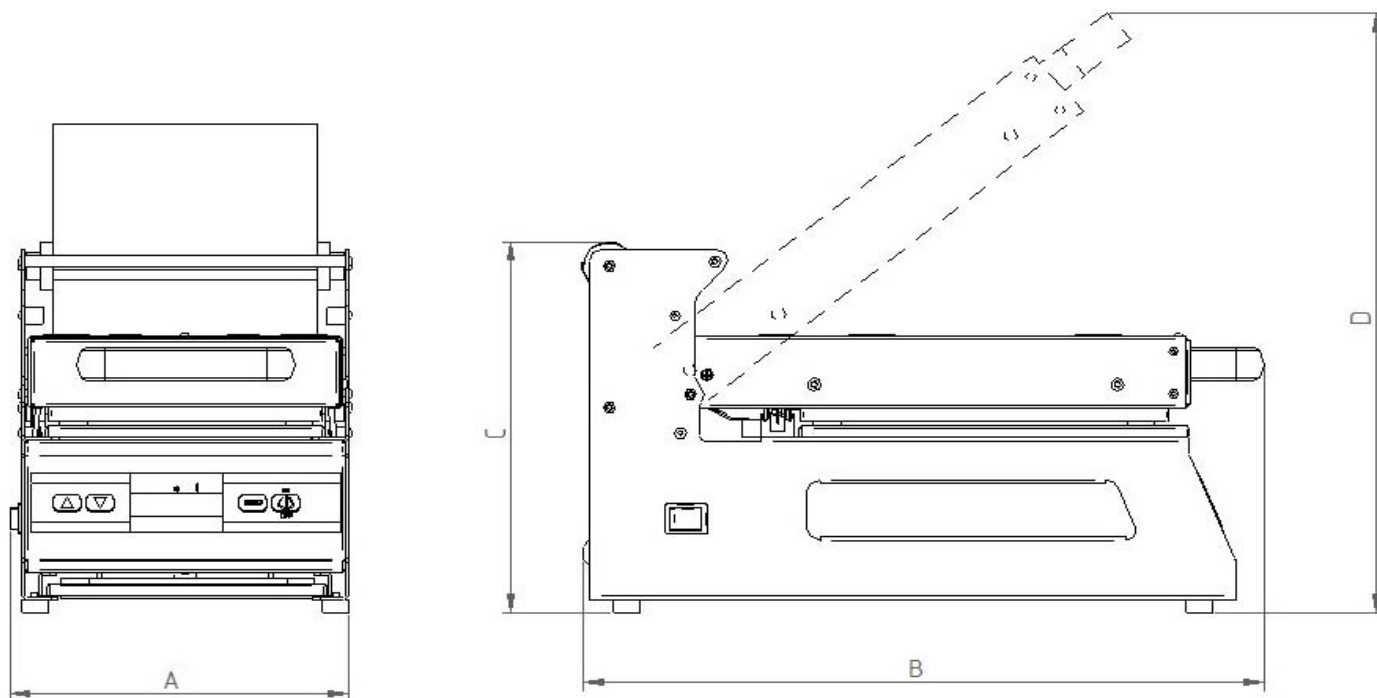

Fig. n°18

TAB. n°1 – SIZE REQUIREMENTS AND TECHNICAL FEATURES

MODEL	<i>U.m.</i>	20
Power	<i>watt</i>	900
Supply		230V/50Hz
Film reels	<i>mm</i>	200
Size Max tray	<i>mm</i>	260x190
A x B	<i>mm</i>	257x525
C	<i>mm</i>	306
D	<i>mm</i>	496
Net weight	<i>kg</i>	18

ATTENTION:

The electrical features, with which the machine is compatible, are shown in a plate applied on the rear of the machine.

CHAP. 7 - INSTALLATION

7.1 – POSITIONING

The surface, on which the machine must be installed, must take into account the bearing sizes, shown on *Tab. 1*, and, therefore, have a sufficient width; it must lean on a well leveled surface, far from water and heat sources, suitable air-conditioning and lighting, in compliance to the space required for use and protection.

Moreover, the machine must be placed in an environment provided with max. 75% non-saline humidity and having a temperature ranging from +5°C to +35°C; in any case, in environments, not entailing malfunctions of the same.

7.2 – ELECTRICAL CONNECTION

Verify that the information on the technical plate-serial number (*Fig. n°19*), in the delivery documents, and on the order match; if not, contact the supplier for explanations.

At this point, verify that the system is compliant with regulations and that the cable and the grounding system are perfectly functioning.

MOD: machine model
 V: Hz: power supply
 A: W: frequency
 KG: amperage power
 ANNO: weight
 date of production

SERIAL NO: n° serial number



Fig. n°19

7.2.1 – Monophase sealer

The machine is provided with a power supply cable, having a section of 3x1mm²; length \cong 3m and a "SCHUKO" plug. Connect the sealer to the 230 V. - 50 Hz voltage, by interposing a thermal magnetic circuit breaker of 10A, $\Delta I= 0.03A$.

7.3 – WIRING DIAGRAM MONOPHASE 230V.

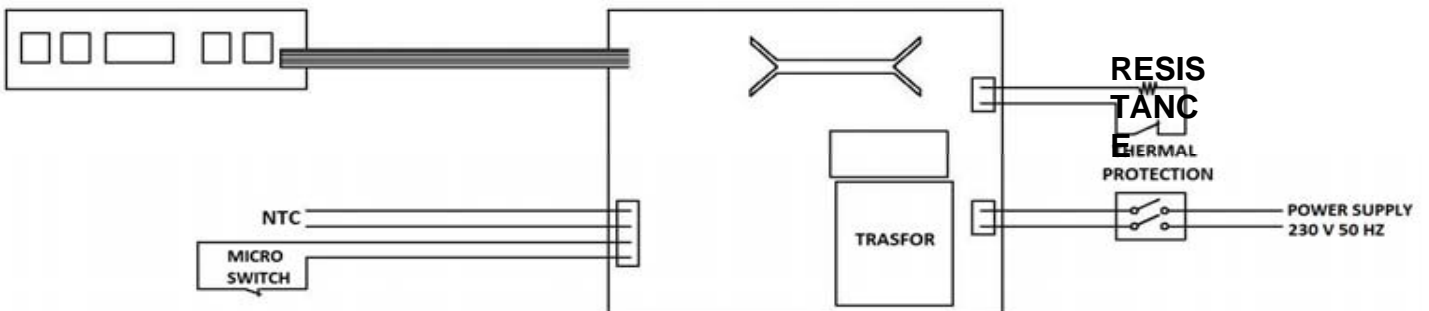

Fig. n°20

CHAP. 8 – USE OF THE MACHINE

8.1 – POSITIONING OF THE FILM (See Fig. n° 21)

ATTENTION! use only sealable film.

Before placing the film reel (a) on the machine, verify the sizes of the same (see Chart n.1).

Remove any protection material from the film reel and place it at the centre of the suitable rollers (b), carefully minding for the initial part of the film, which must be unrolled.

Take the initial edge of the film, pass it over the first roller (c) and, then, slowly pulling it downwards, passing it under the roller (d) and, then, under the film-pressing sheet (e). Pull it in case of need until covering the entire tray to seal.

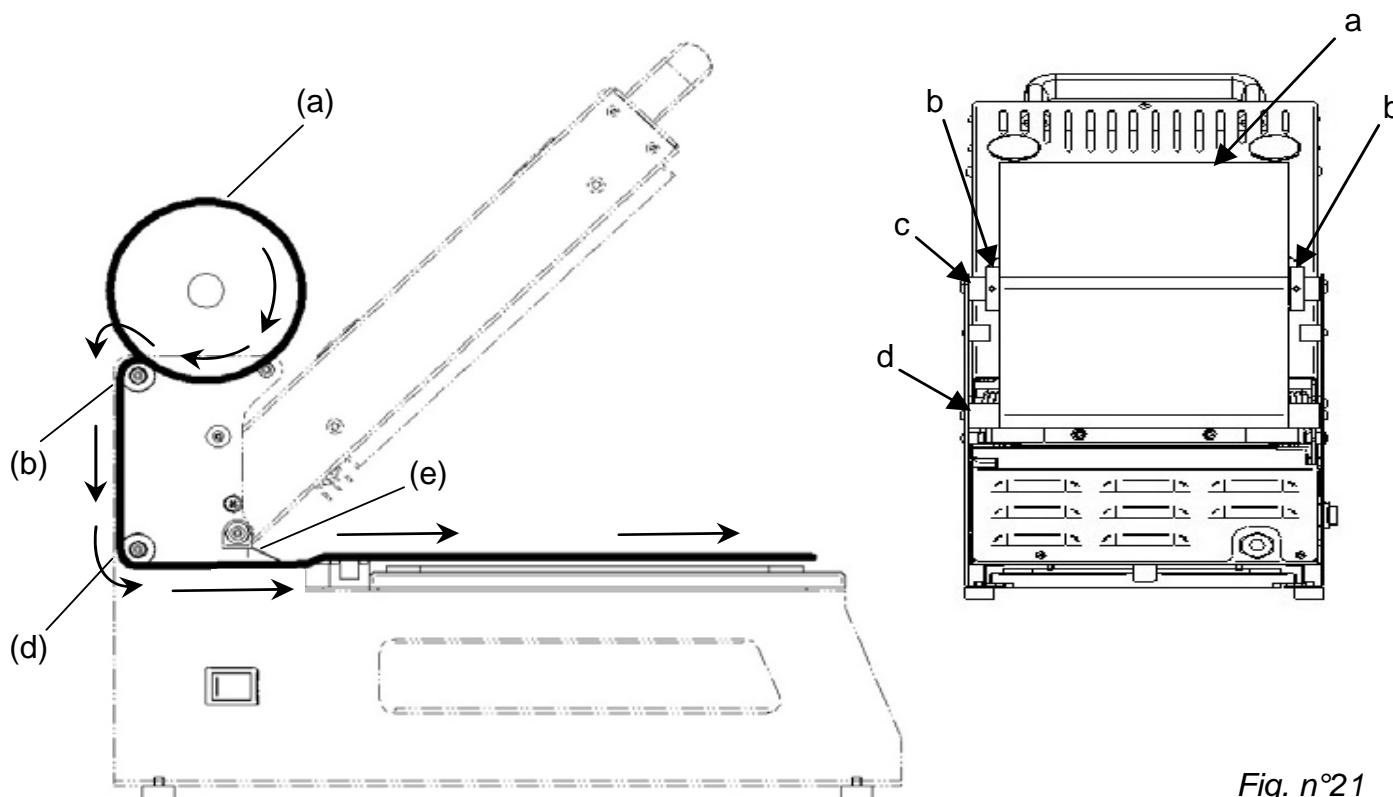

Fig. n°21

8.1.2 Positioning of the mould

(See Fig. n°22)

Before starting to seal, it is necessary to verify whether the mould is placed in the correct position.

Place the mould in the appropriate space and match the holes of the same with the two pegs present on the sealer.

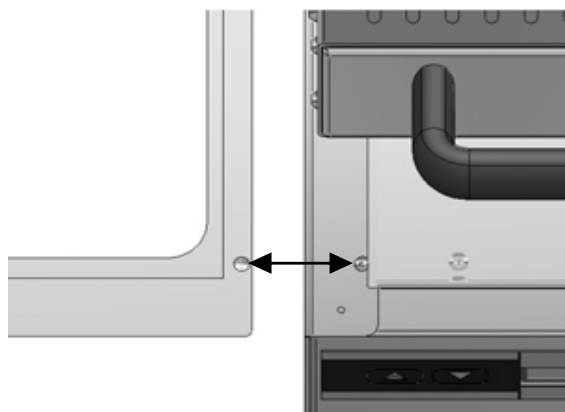

Fig. n°22

8.2 – PRELIMINARY CHECKS

Before proceeding with the testing, place the film correctly (see par. n°8.1), then, test the functioning with the following procedure (see Fig. n°23):

- turn on the machine by selecting the general switch "ON/OFF" (1) on the position "ON";
- The display (4) turns on and the wording "STOP" is displayed.
- Pressing the "MENU" key (3) once, it is possible to modify the sealing time, by pressing again, it will be possible to modify the temperature of the welding plate to reach.
- After setting the parameters according to one's needs, pressing the "ON/OFF" key (2), the welding plate will start to heat up.
- Wait for it to reach the set temperature.
- Shut the machine off by selecting the general switch "ON/OFF" (1) on the "OFF" position.

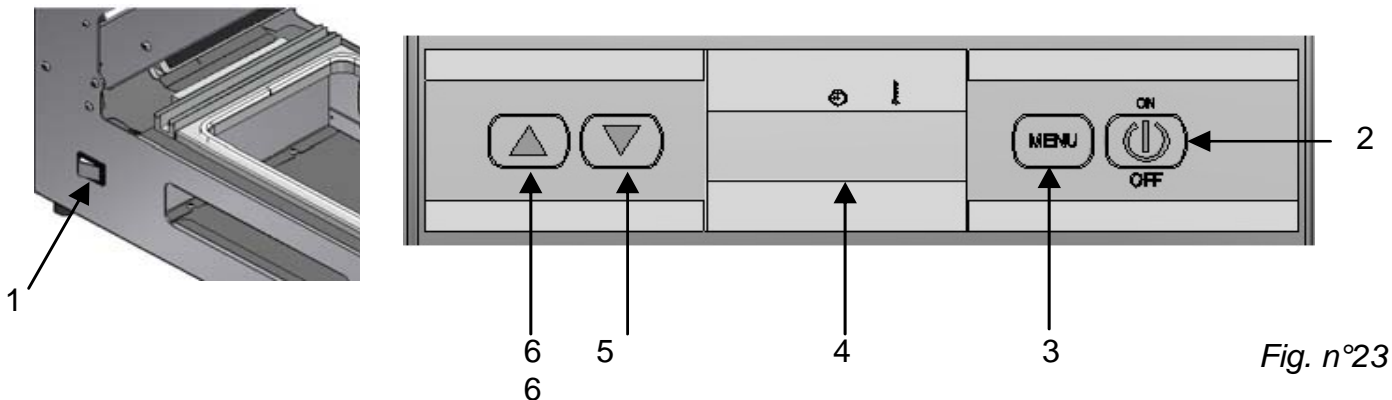

Fig. n°23

Legend:

- | | |
|----------------------|------------|
| 1 Main ON/OFF switch | 4 Display |
| 2 ON/OFF Key | 5 DOWN key |
| 3 MENU Key | 6 UP key |

CHAP. 9 – USE OF THE MACHINE

9.1 – STARTUP OF THE MACHINE

9.1.2 – Setting of the use parameters:

- Pressing the general switch "ON/OFF" (1) the sealer turns on (Fig. n°24).



Fig. n° 24

- The sealer displays the status of the machine (a), the time for the sealing of the tray (d), the preset temperature (b), the current temperature of the welding plate (e) and the number of cycles (c) (Fig.n°25).
- In the "STOP" mode, press the "MENU" key (ref. 3 fig.n°23) to modify the time, press it again to modify the temperature. Use the UP (ref. 6 fig. n° 23) and DOWN (rif. 5 fig. n°23) buttons to modify the parameters.
- To reset the number of cycles, press twice the "UP" button (rif.6 fig. n°23), resetting can be carried out only in the "STOP" mode.
- Pressing the "ON/OFF" button (rif. 2 fig. n°21), the sealer turns on, the machine status will pass from "WAIT", it will start to heat up the welding plate until it reaching the set temperature (Fig. n° 26).
- Once the temperature is reached, the machine is ready to seal with the set configurations (Fig. n° 27). The machine status will read "READY".

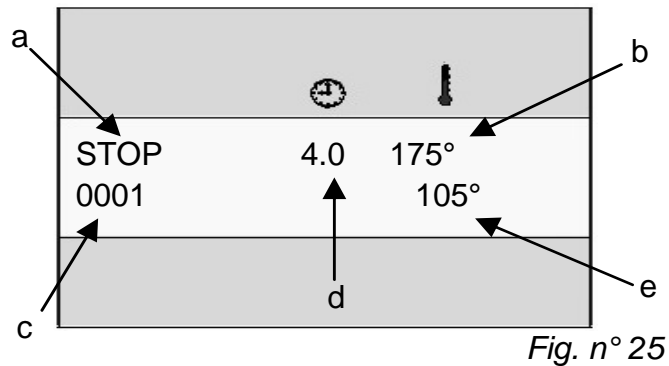

Fig. n° 25

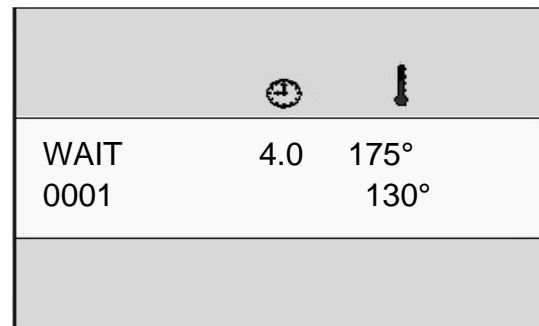

Fig. n°26

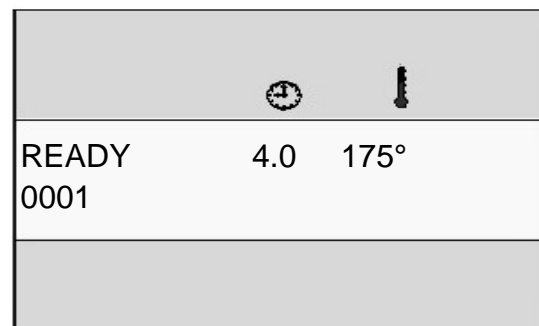

Fig. n°27

9.1.3 - Sealing – procedure

The machine is ready only if the display shows the "READY" mode. (Fig. n°26)

1. Verify that the film reel is correctly in-serted (read par. 8.1).
2. Insert the tray on the appropriate slot and, then, load the product to seal in-side the tray requiring sealing (Fig. n°28).



Fig. n°28

ATTENTION: top plate very hot!

3. Pull the film correctly above the tray to seal (*Fig. n°29-30*). **PAY ATTENTION to the knife for the cut of the film!**



Fig. n°29



Fig. n°30

4. Lower the welding head until it closes completely, after hearing a “beep” signal the sealing procedure starts for the duration previously set (*Fig. n°31*).

5. The display will show the machine status on “RUN” mode as well as the elapsed seconds of the cycle (*Fig. n°31*).

6. Upon reaching the sealing time set, you will hear two consecutive “beeps” warning that the operation has been completed.

7. Shall the welding head be open before the completion of the sealing, it will emit a series of fast “beep” signals to warn that the operation has not been completed. It is recommended to repeat the operation.

8. Lift the welding head.

9. Pull out the tray by hand in the side openings (*Fig. n°32*) **ATTENTION** do not touch the welding plate.

10. Now, it is possible to carry out a new cycle.

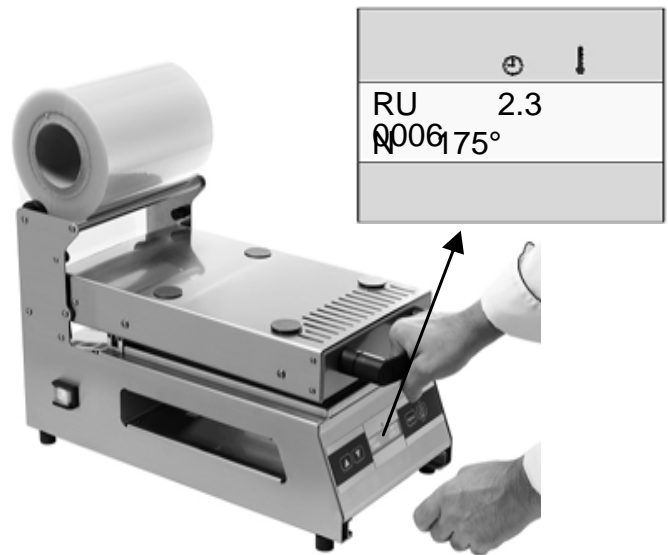

Fig. n°31



Fig. n°32

CHAP. 10 – ISSUES AND SOLUTIONS

(See Fig. n°33)

10.1 – POSSIBLE ERRORS

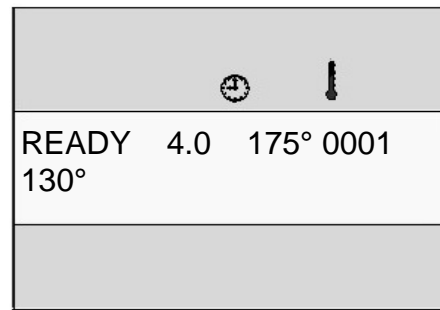
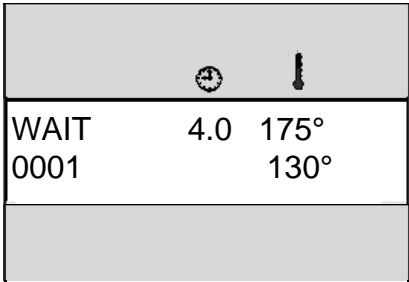

Fig. n°33

Error	Cause	Solutions
E1		Wait for the machine to be in the READY mode to seal the tray correctly.
E2	A series of consecutive “beep” signals during sealing	The sealing operation has not been completed correctly It is advisable to perform the operation again.

CHAP. 11 – ROUTINE CLEANING

11.1 - GENERALS

- Machine cleaning is an operation, which must be carried out, in case of contact with the processed product.
- The tray sealers must not be cleaned with high pressure water jet cleaners or water jets, but with neutral detergents (pH 7). **Any other detergent product is forbidden.** Tools, scrubbing brushes and other may damage the surface of the machine.

Before performing any cleaning operation, it is necessary to:

- **disconnect the power supply plug from the mains to completely isolate the rest of the system and wait for it to cool off.**

11.2 – MACHINE CLEANING

The cleaning of the drawer must be carried out in case of need and it must be performed with hot water and with the support of a sponge. Carefully dry each element, at the end of the cleaning operation.

To proceed with the cleaning of the machine from the outside, use a slightly soaked sponge with a small quantity of detergent and an odourless and non-harmful sanitizer.

Do not use abrasive detergents, anti-scaling detergent creams, solvents and diluents; the residues of such products may dangerously contaminate food substances during following processing.



ATTENTION!



CHAP. 12 - DISMANTLING

Fig. n°34



ATTENTION!

12.1 - DECOMMISSIONING

If, for some reason, it is decided to disable the machine, make sure that it cannot be used by any person: **disconnect and cut electrical connections.**

12.2 - WEEE Waste of electric and electronic equipment



In accordance with art.13 of the Legislative Decree dated 25 July 2005 ,n.151 "Implementation of Directives 2002/95/CE, 2002/96/CE e 2003/108/CE, relating to the reduction of the use of hazardous substances in electrical and electronic equipment, as well as to waste disposal".

The symbol of the crossed out waste bin on the product and its packaging indicates that at the end of its useful life, the product must be disposed of separately from other waste.

Sorted waste disposal of products at the end of their useful life is organised and managed by the manufacturer. The user should dispose of this equipment contacting the manufacturer and following the system adopted by the latter to allow the separate collection of the equipment at the end of its service life.

The suitable recycling for a further conveyance of the dismantled equipment, to recycling, to treatment and to environmentally compatible disposal contributes to avoid possible negative effects on the environment and on health and promotes the re-use and/or recycling of materials, of which the equipment is made.

The illegal disposal of a product is punishable according to the laws currently in force.

***SERVICE CENTRE
AUTHORISED DEALER***

CHAP. 6 - TECHNICAL DATA

6.1 – SIZE REQUIREMENT, WEIGHT, FEATURES ...

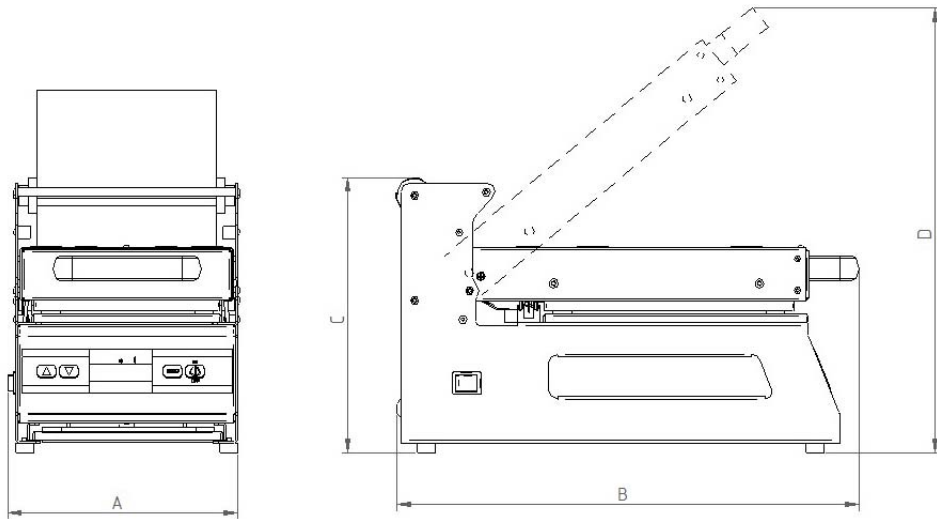

Fig. n°18

TAB. n°1 – SIZE REQUIREMENTS AND TECHNICAL FEATURES

MODEL	<i>U.m.</i>	20
Power	<i>watt</i>	900
Supply		230V/50Hz
Film reels	<i>mm</i>	200
Size Max tray	<i>mm</i>	260x190
A x B	<i>mm</i>	257x525
C	<i>mm</i>	306
D	<i>mm</i>	496
Net weight	<i>kg</i>	18

ATTENTION:

The electrical features, with which the machine is compatible, are shown in a plate applied on the rear of the machine.

CHAP. 4 – ABOUT THE MACHINE

4.1 – CONSTRUCTION FEATURES

The machine mainly consists in a stainless steel structure AISI 304, whereas the welding plate consists in Teflon-coated aluminium.

4.2 – DESCRIPTION OF THE MACHINE

Tray sealers have been designed and implemented by the same firm with the exact purpose of sealing food inside trays for food use and assure:

- maximum safety as for use, cleaning and maintenance;
- maximum hygiene, achieved owing to a detailed selection of the materials, which enter into contact with the food;
- firmness and stability of all the components.

4.3 – MACHINE COMPOSITION

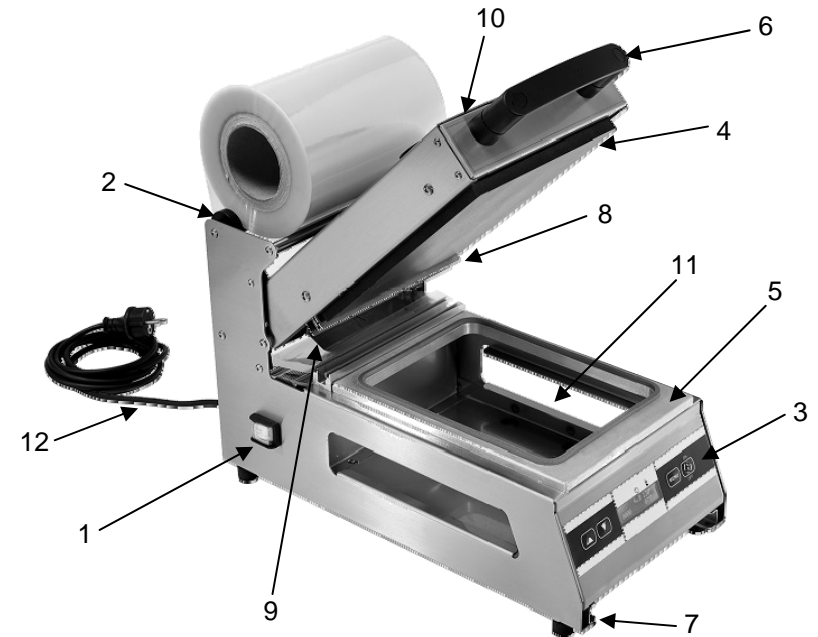

Fig. n°9

Legend

- | | |
|-----------------------------|-----------------------|
| 1 Main ON/OFF switch | 7 Slot for mould |
| 2 Film reel support rollers | 8 Cutter |
| 3 Control board | 9 Film-pressing sheet |
| 4 Sealing plate | 10 Sealing head |
| 5 Tray mould | 11 Tray chamber |
| 6 Handle | 12 Power cord |

CHAP. 5 – TRASPORT PACKAGING AND UNPACKAGING

5.1 – PACKAGING

The packaging, in which the machine is shipped, is made up of (Fig. n°10): cardboard box, protection nylon material and cardboard inserts. Therefore, they shall be disposed separately and in compliance with the regulations in force in the installation country.

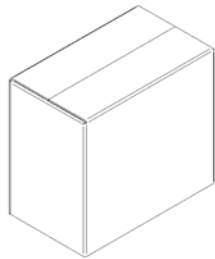

Fig. n°10

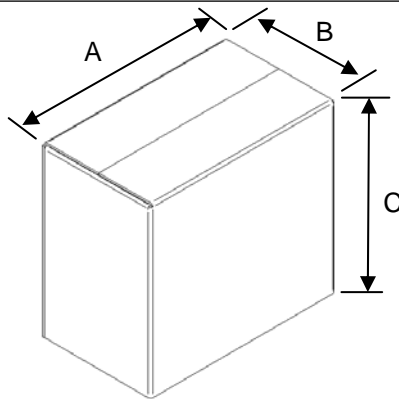

Fig. n°11

Dimensions AxBxC (mm)	Gross weight (Kg)
620x380x400	22



Do not leave the packaging exposed to humidity and rain (Fig. n°12).

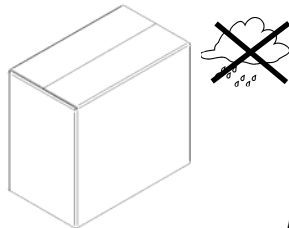

Fig. n°12



Heavy packaging. Do not lift manually without the support of minimum two people (Fig. n°13).

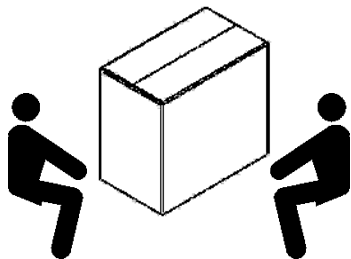

Fig. n°13



WARNING!

Do not stack up more than two packagings. (Fig. n°14).

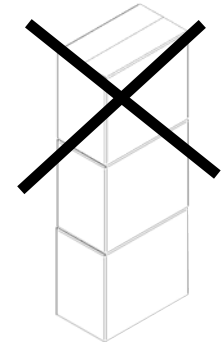

Fig. n°14

5.2 – CHECK OF THE PACKAGING UPON RECEIPT

Upon received of the package, shall it not feature external damages, proceed with its opening and check that all the material is present inside. On the contrary, if upon delivery the parcel features signs of mistreatment (Fig. n°15), collision or fall, it is necessary to inform the courier about the damages, and within three days from the delivery date, shown on the documents, draw up an accurate report on any damages undergone by the machine.

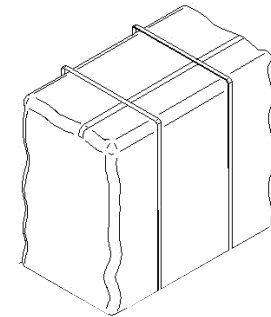

Fig. n°15

Do not overturn the packaging!! Upon transportation, make sure that it is grabbed firmly from the 4 corners (thus keeping it parallel to the floor).



WARNING!

All the operations must be carried out by the specialized technical personnel (Fig. n°16).



Fig. n°16

5.3 – UNPACKAGING

Open the box (Fig. n°17), remove the protection nylon material from the machine and lift it up carefully.

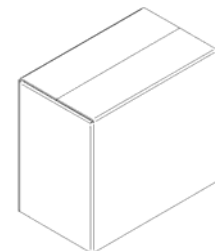

Fig. n°17